

# AIRNET



## *Installation and Assembly Guide*

[www.airnet-system.com](http://www.airnet-system.com)

**fast** ..... **easy** ..... **reliable**

Operating Conditions & Safety Instructions ..... 3

Expansion Loops..... 4

Installation..... 5-18

- Ø 20 - 50 mm / 3/4" - 2" (PF Series)..... 5
- Ø 63 - 80 mm / 2 1/2" - 3 1/2" (Classic) ..... 7
- Ø 100 mm / 4" ..... 9
- Ø 158 mm / 6" ..... 11
- Quickdrops (Ø 20 - 80 mm / 3/4" - 3")..... 13
- Replacing Classic Series with PF Series ..... 14
- Pipeclips Installation..... 15
- Valve Support..... 16
- Conductivity Strip..... 17
- Adapter Union..... 18

## OPERATING CONDITIONS

- AIRnet is designed to convey compressed air, nitrogen, and vacuum.
- AIRnet pipes and fittings should be protected against rain, snow, and guano.
- AIRnet pipes and fittings must be appropriately protected against violent impacts.
- AIRnet pipes and fittings are not suitable for direct contact with soil.
- AIRnet pipes and fittings should not be used as support for electrical equipment or earth conductors.
- AIRnet pipes should never be connected directly to a source of vibrations, use hoses instead.
- AIRnet fittings are sensitive to direct UV radiation. In case of direct exposure, shield the fittings. (AIRnet pipes offer excellent resistance to UV radiation.)

## SAFETY INSTRUCTIONS

- Installation, operation, and repair work of an AIRnet system must be performed by authorised, trained, specialised personnel.
- The installer must employ safe working practices and observe all related local work safety requirements and regulations.
- Before any installation, maintenance, repair work, adjustment or any other non-routine checks, relieve the AIRnet system of pressure and effectively isolate the system from all sources of pressure.
- Only genuine AIRnet parts should be used when installing or repairing an AIRnet system.
- All plugs and caps must be removed before installing the AIRnet pipes.
- Check the surface of the AIRnet pipes before installing. There should be no relevant scratches, abrasions, dents etc.
- Use only solvents or chemicals which do not damage the materials of AIRnet.
- Before using the AIRnet system, an installer must ensure that all necessary test controls and applicable rules for the specific installation (compressed air, nitrogen or vacuum) are compiled.
- At initial start up of the AIRnet system, apply a test pressure of 1.5 bar to identify leakage or imperfect joints. After performing an inspection, increase the pressure gradually and constantly (max. 1 bar every 30 seconds) and perform a second inspection for leakages or imperfect joints at the final pressure.

Long straight pipes can expand or contract due to temperature variations. To compensate for this effect, expansion loops are required. The number of expansion loops depends on the total length of the straight line and the maximum temperature variation. An expansion loop is a U-shaped construction that compensates the variation in length. They look like this:

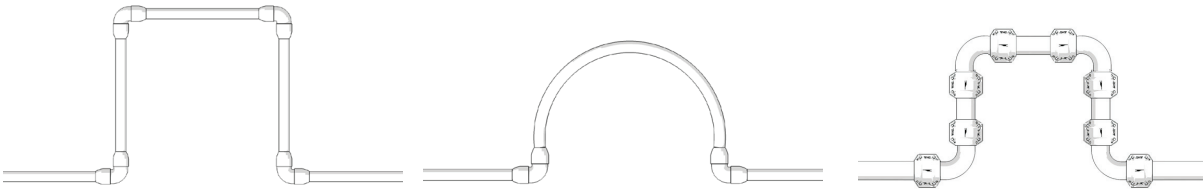

The below table clarifies the maximum possible straight distance vs. the temperature variation. When the length of the straight line exceeds the maximum, expansion loops are required to compensate for the variation in length.

$\Delta T$	$\varnothing 20 \text{ mm} / 3/4''$	$\varnothing 25 \text{ mm} / 1''$	$\varnothing 40 \text{ mm} / 1\frac{1}{2}''$	$\varnothing 50 \text{ mm} / 2''$	$\varnothing 63 \text{ mm} / 2\frac{1}{2}''$	$\varnothing 80 \text{ mm} / 3''$	$\varnothing 100 \text{ mm} / 4''$	$\varnothing 158 \text{ mm} / 6''$
<b>5°C / 9°F</b>	211 m / 692 ft	168 m / 551 ft	187 m / 614 ft	150 m / 492 ft	119 m / 390 ft	94 m / 308 ft	75 m / 247 ft	47 m / 154 ft
<b>10°C / 18°F</b>	159 m / 522 ft	127 m / 417 ft	141 m / 463 ft	113 m / 371 ft	90 m / 295 ft	71 m / 233 ft	57 m / 186 ft	36 m / 118 ft
<b>20°C / 36°F</b>	107 m / 351 ft	85 m / 279 ft	95 m / 312 ft	76 m / 249 ft	60 m / 197 ft	47 m / 154 ft	38 m / 123 ft	24 m / 79 ft
<b>30°C / 54°F</b>	80 m / 262 ft	64 m / 210 ft	71 m / 233 ft	57 m / 187 ft	45 m / 148 ft	36 m / 118 ft	29 m / 94 ft	18 m / 59 ft
<b>40°C / 72°F</b>	64 m / 210 ft	52 m / 171 ft	57 m / 187 ft	45 m / 148 ft	36 m / 118 ft	29 m / 95 ft	23 m / 76 ft	14 m / 46 ft

**Diameters 20-50mm / 3/4" - 2"**  
(PF Series)

**1 MEASURE**

Length  $L = l + (2 \times S)$

length (l)

S

Ø	S
20mm / 3/4"	39mm / 1 1/2"
25mm / 1"	44mm / 1 3/4"
40mm / 1 1/2"	63mm / 2 1/2"
50mm / 2"	78mm / 3 1/16"

**2 CUT**

OR

Ø 20-63 mm 2810 0040 00

110/120V 2810 0640 80

220/230V 2810 0540 80

**3 CHECK**

$\leq 10^\circ$

CHECK

**4 DEBURR**

OR

Ø 20-50 mm 2810 0141 00

ALL 2810 0641 00

**5 MARK**

ALL 2811 0029 80

**Diameters 20-50mm / 3/4" - 2"**  
**(PF Series)**

**(OPTIONAL: LOOSEN)**

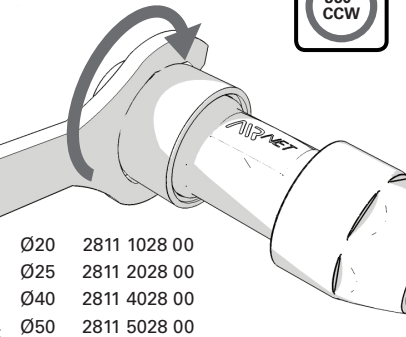

360°  
CCW

Ø20	2811 1028 00
Ø25	2811 2028 00
Ø40	2811 4028 00
Ø50	2811 5028 00

**6 LUBRICATE**

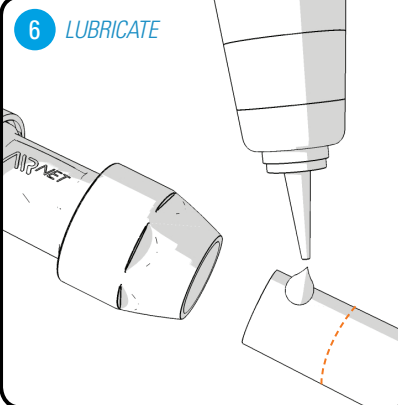

ALL 2810 0148 00

**7 INSERT**

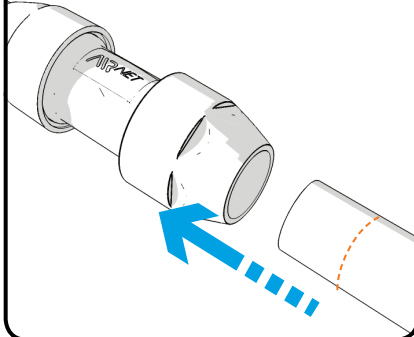

**8 CHECK**

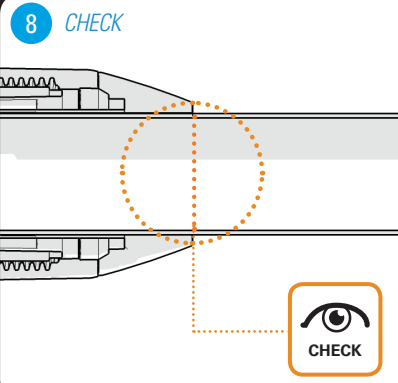

CHECK

**(OPTIONAL: TIGHTEN)**

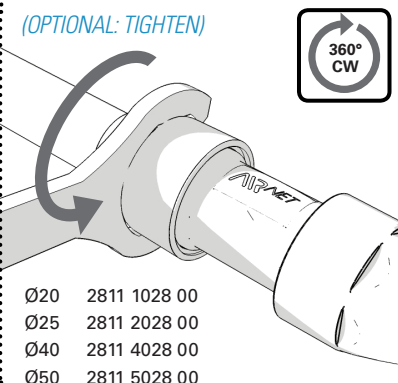

360°  
CW

Ø20	2811 1028 00
Ø25	2811 2028 00
Ø40	2811 4028 00
Ø50	2811 5028 00

**9 CHECK MARKERS**

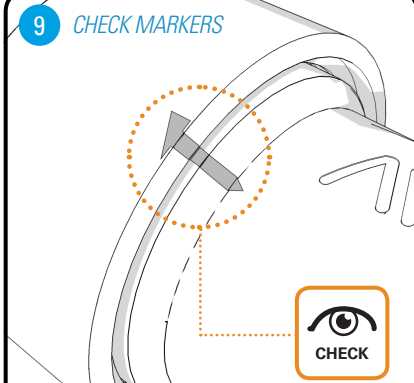

CHECK

**Diameters 63 - 80mm**  
**2 1/2" - 3" (Classic)**

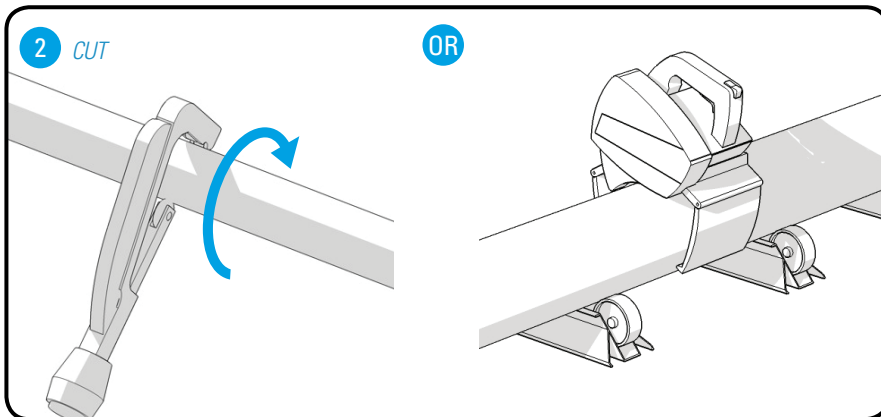
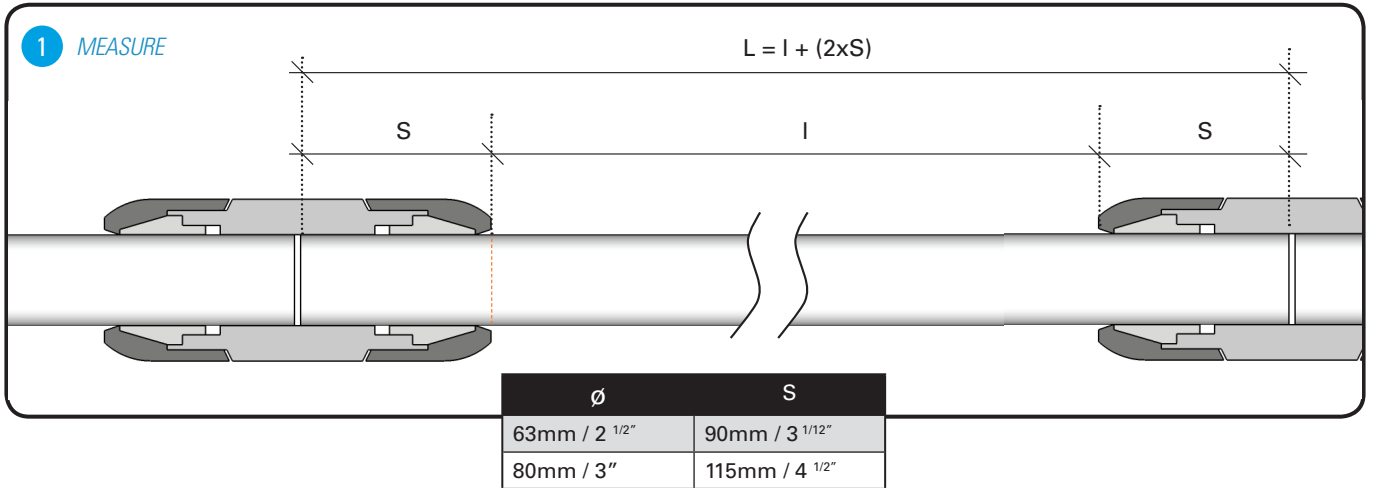

$\varnothing$  40-100 mm    2810 0140 00  
 $\varnothing$  20-63 mm    2810 0040 00

110/120V    2810 0640 80  
 220/230V    2810 0540 80

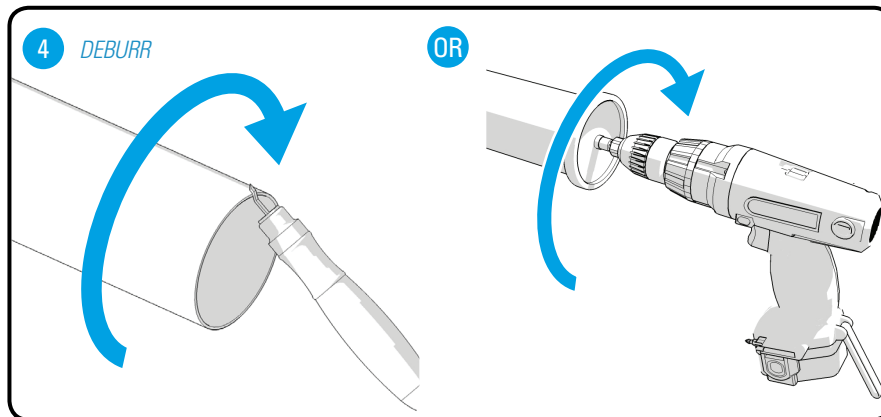
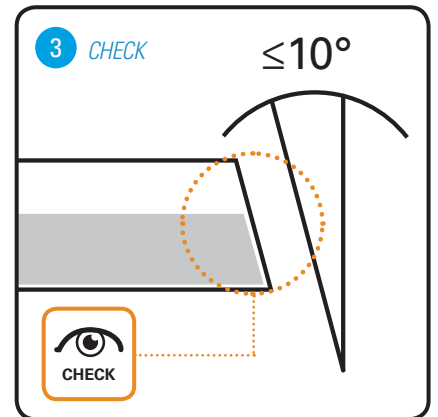

ALL    2810 0641 00

ALL    2810 0741 00

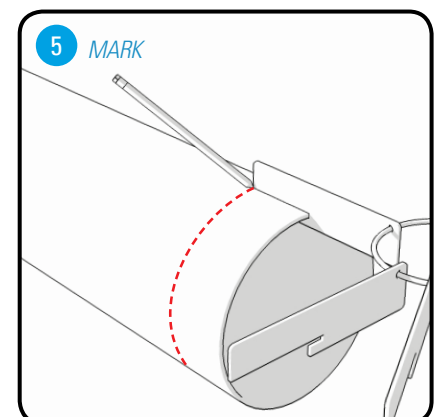

ALL    2811 0029 80

## Diameters 63 - 80mm 2 1/2" - 3" (Classic)

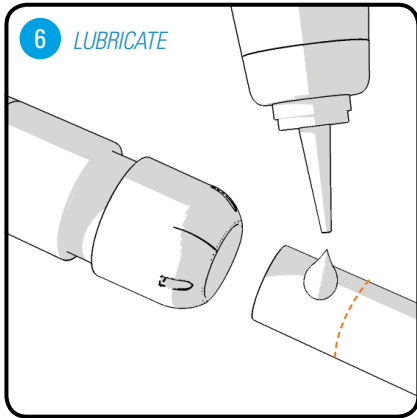

ALL 2810 0148 00

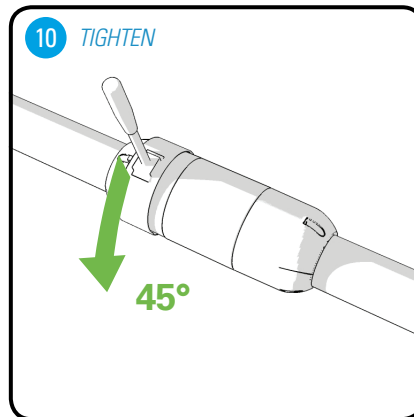
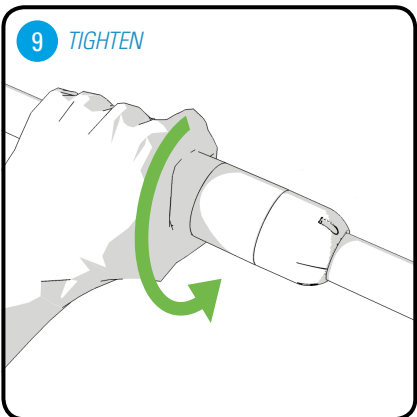
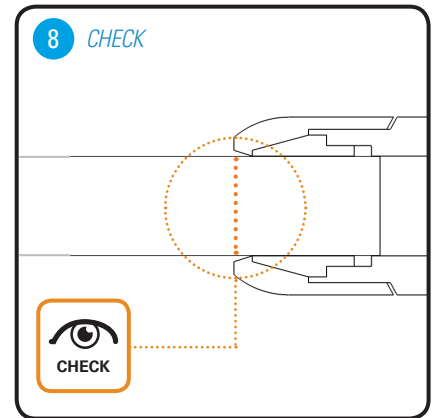
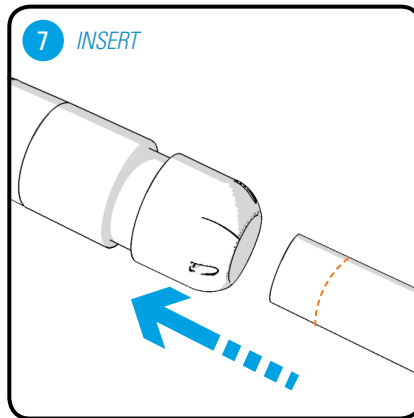

Ø 63 mm 2810 6028 00

Ø 80 mm 2810 7028 00



**Diameter 100mm / 4"**

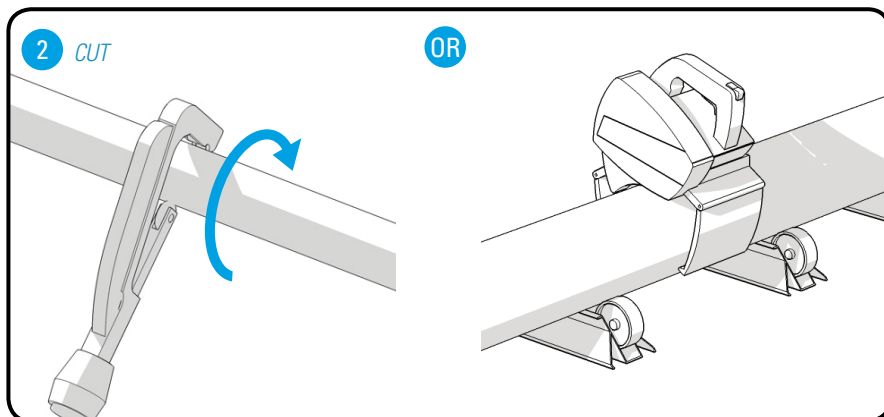
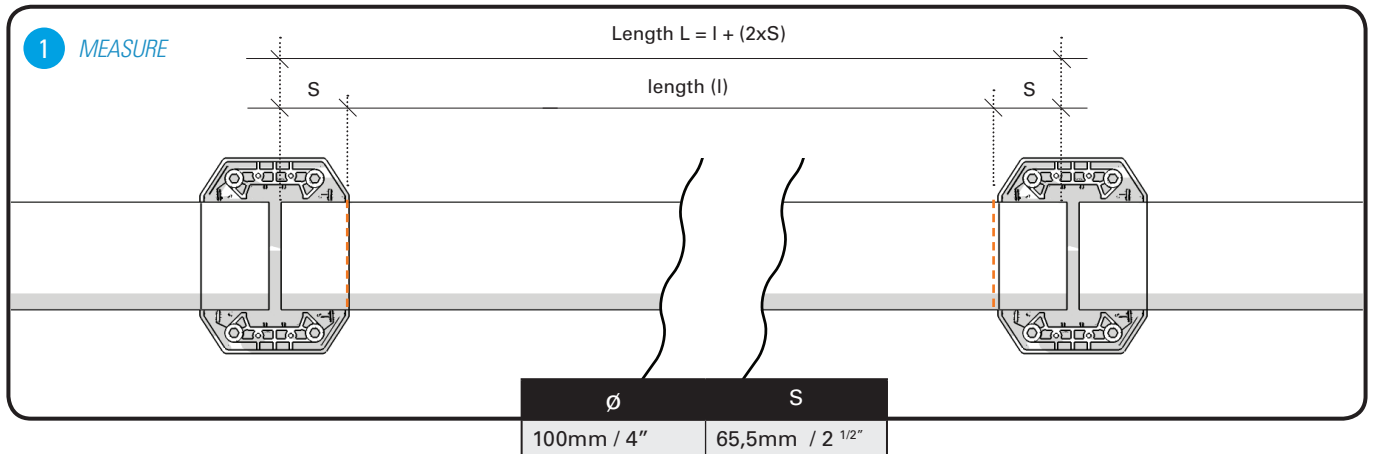

Ø 40-100 mm 2810 0140 00

110/120V 2810 0640 80

Ø 100-158 mm 2810 0240 00

220/230V 2810 0540 80

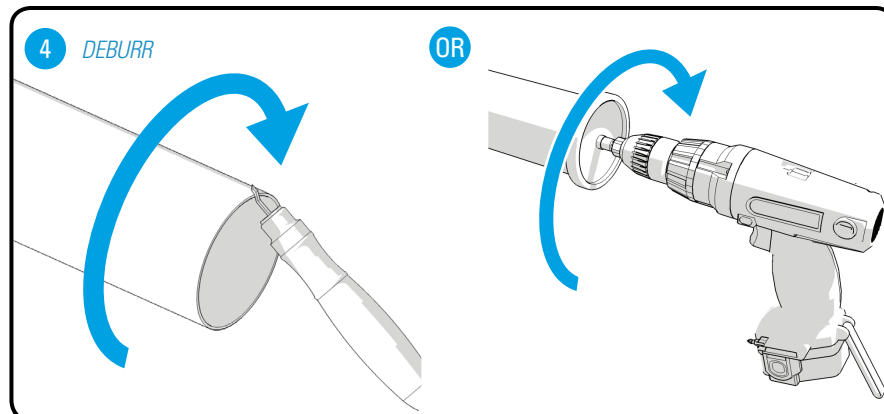
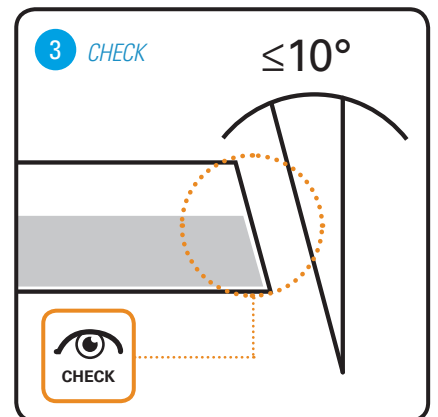

ALL 2810 0641 00

ALL 2810 0741 00

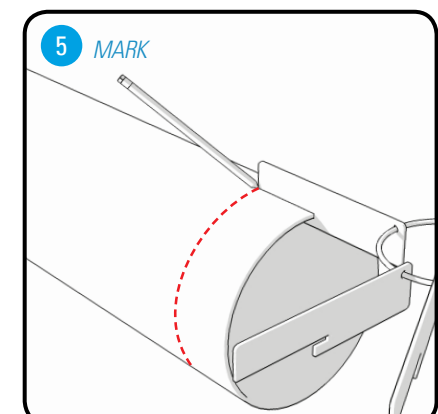

ALL 2811 0029 00

**Diameter 100mm / 4"**

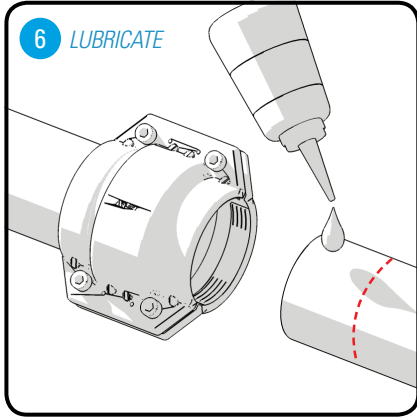

ALL 2810 0148 00

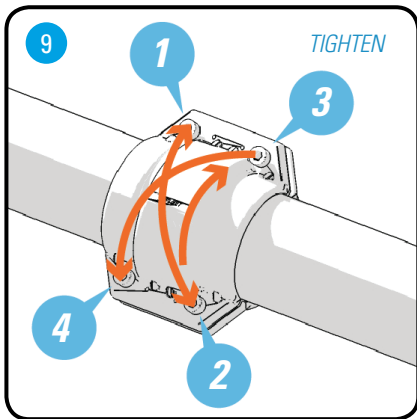
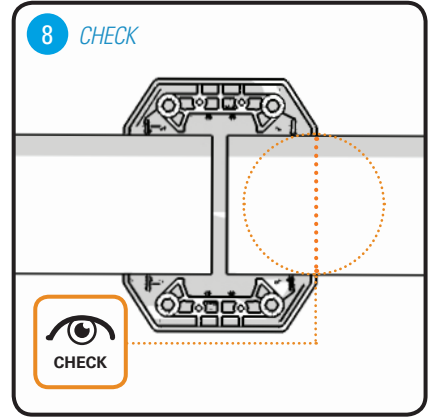
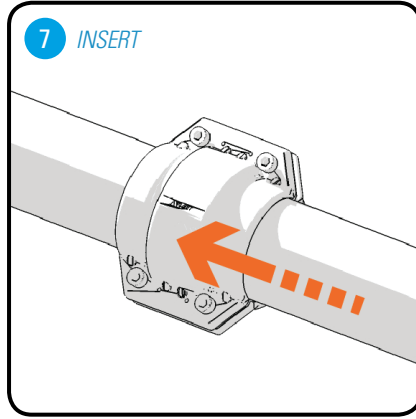

Wrench 0462 7094 21  
Head 0462 1011 05

0-5 Nm  
0-3.7 lbs/ft

**40 Nm**

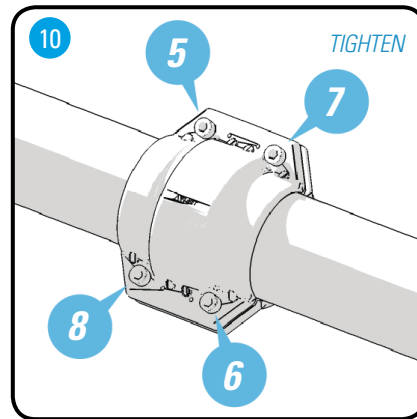

Wrench 0462 7094 21  
Head 0462 1011 05

40Nm  
29,5 lbs/ft

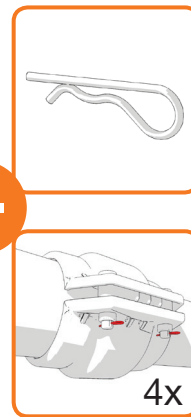
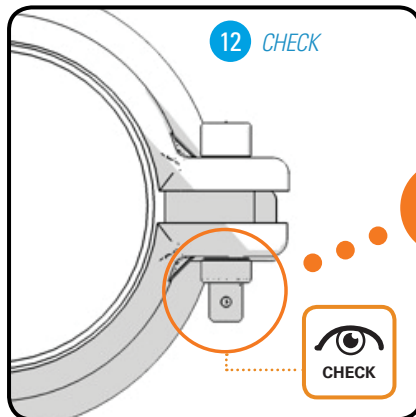
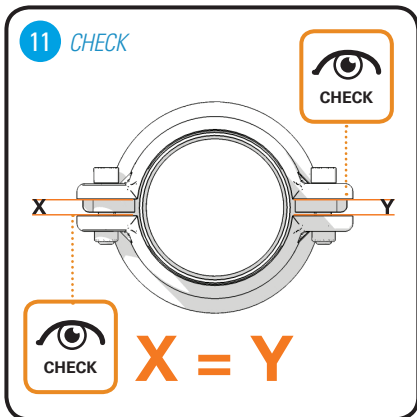

**Diameter 158mm / 6"**

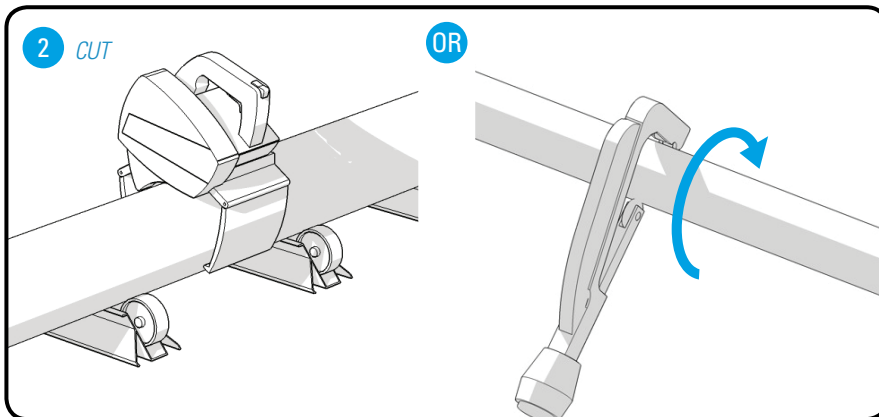
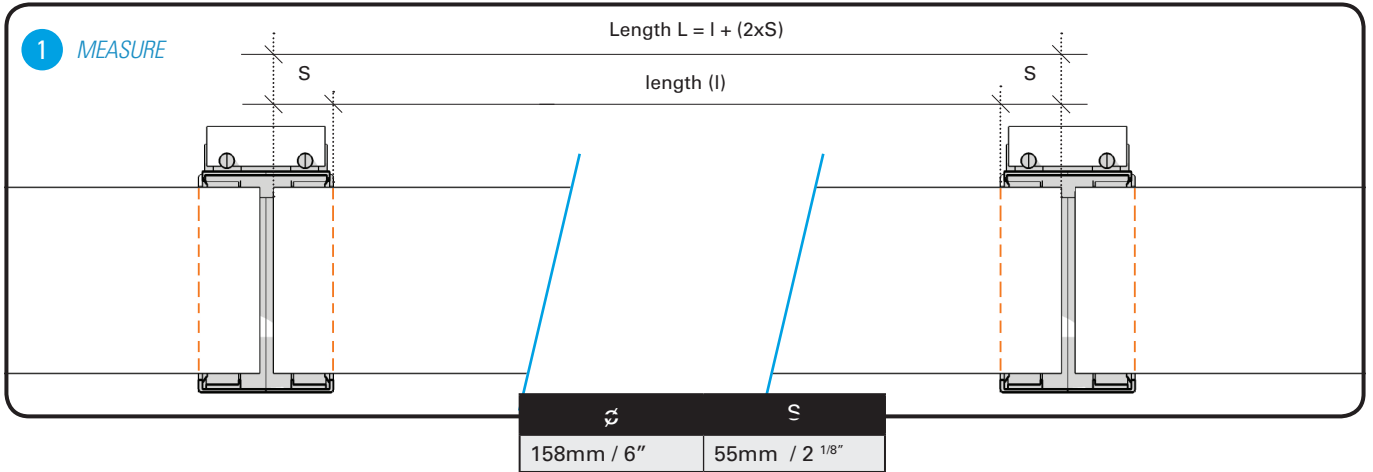

110/120V 2810 0640 80

Ø 100-158 mm 2810 0240 00

220/230V 2810 0540 80

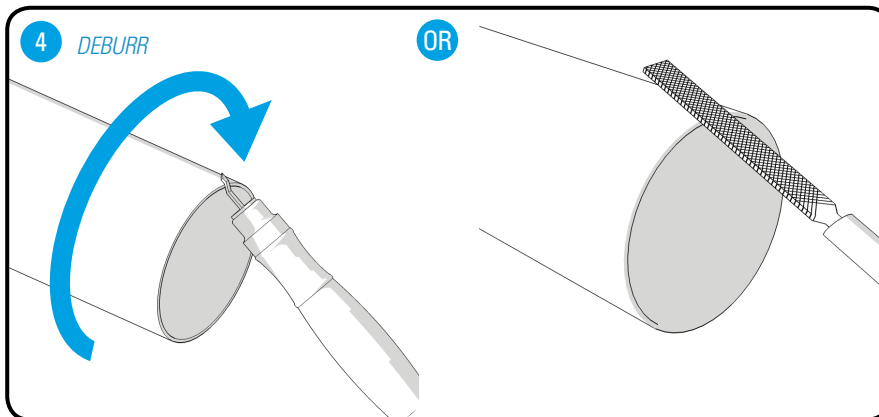
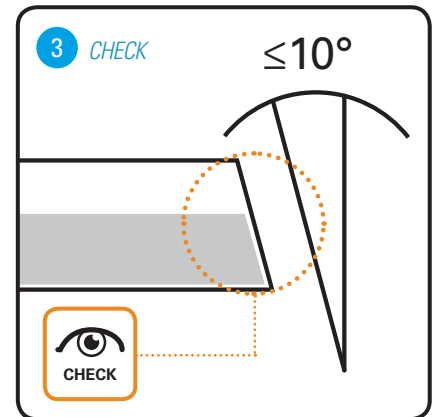

ALL 2810 0641 00

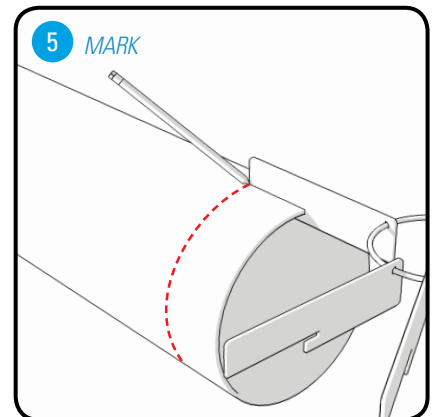

ALL 2811 0029 00

## Diameter 158mm / 6"

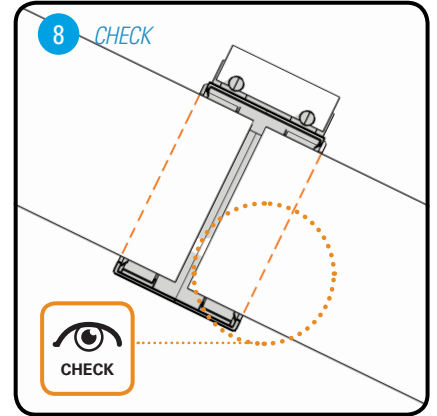
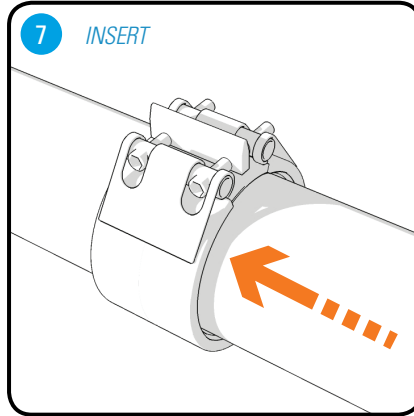
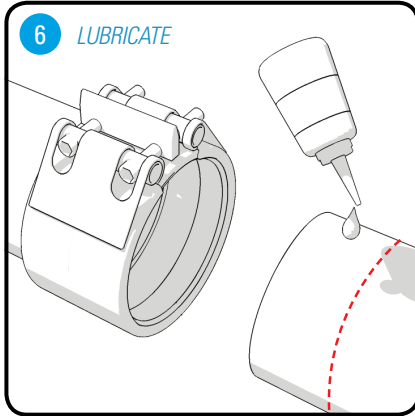

ALL 2810 0148 00

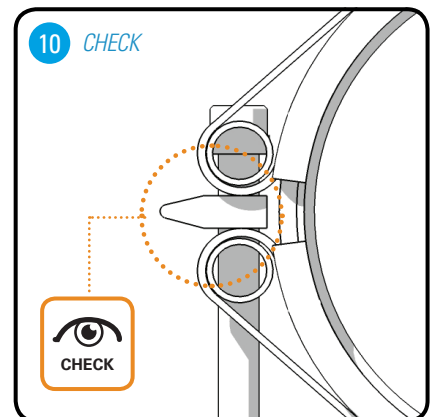
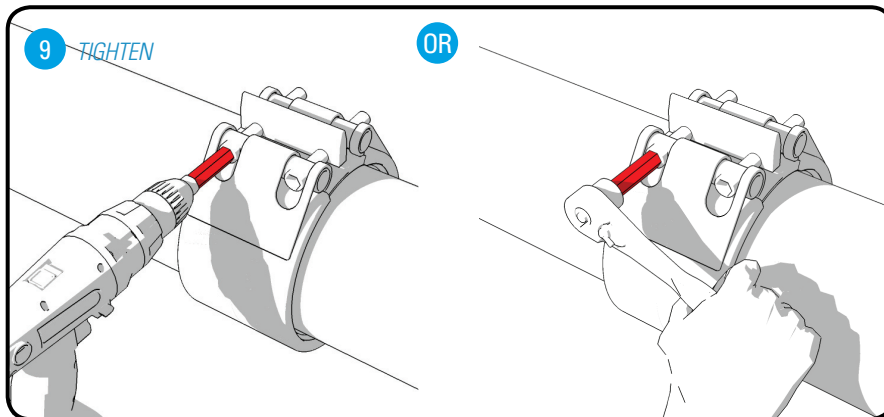

Hexagon Socket 0462 3601 23

## Quick Drop Assembly

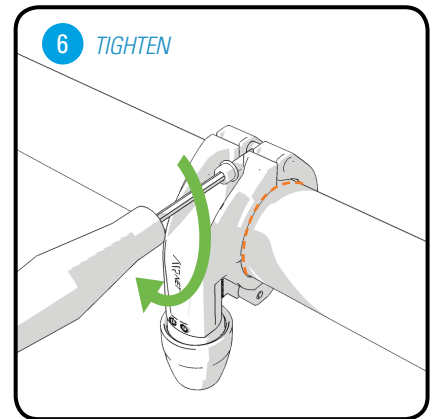
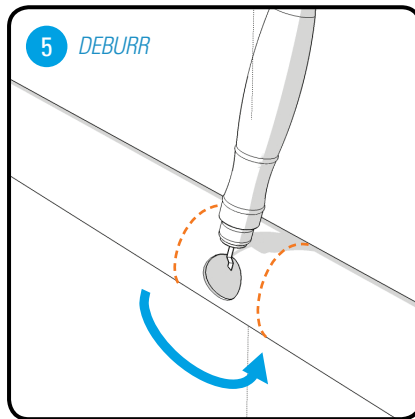
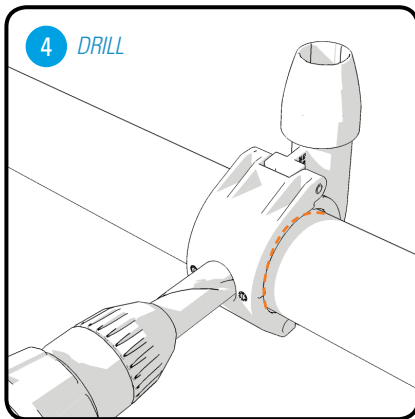
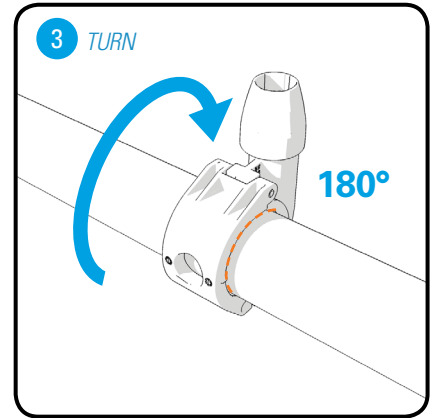
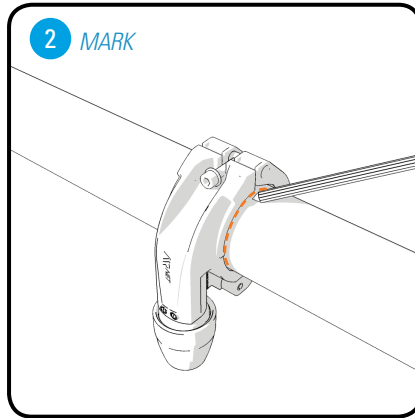
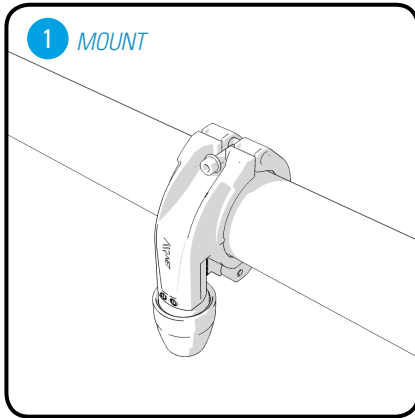

Ø 25 mm drill bit 2810 0143 00

ALL 2810 0641 00





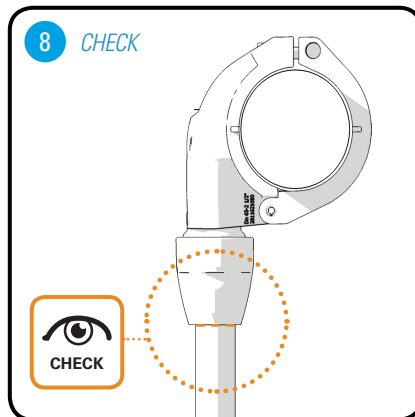
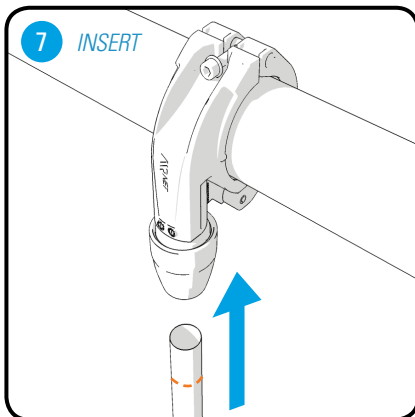

Classic 2810 0049 00

Ø 40-80 mm drill bit 2810 0243 00

PF Series 2811 0149 00

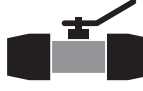

## Replace Classic Series with new PF-Series

$\Delta$						
$\varnothing$ 20mm	21,5mm	9mm	9mm	8mm	8mm	13mm
$\varnothing$ 25mm	19mm	14,5mm	13mm	6mm	8mm	20mm
$\varnothing$ 40mm	38mm	23mm	28mm	23mm	9mm	35mm
$\varnothing$ 50mm	37,5mm"	32mm	35mm	32mm	0mm	34mm
$\varnothing$ 3/4"	7/8"	3/8"	3/8"	1/4"	1/4"	1/2"
$\varnothing$ 1"	3/4"	1/2"	1/2"	1/4"	1/4"	3/4"
$\varnothing$ 1 1/2"	1 1/2"	7/8"	1 1/8"	7/8"	3/8"	1 3/8"
$\varnothing$ 2"	1 1/2"	1 1/4"	1 3/8"	1 1/4"	0"	1 3/8"

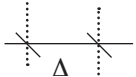
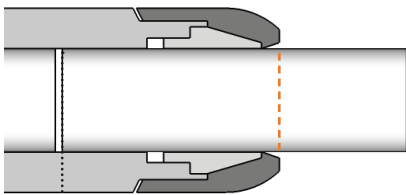

$\Delta$  = Length to be cut off before replacement

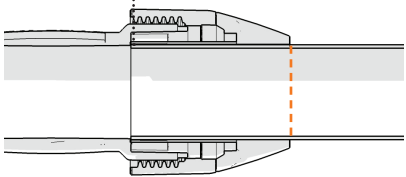

**Pipe Clips Installation (Ø20 - Ø158)**

**Rule #1: maximum 2,5 m/ 8 ft between 2 pipeclips**

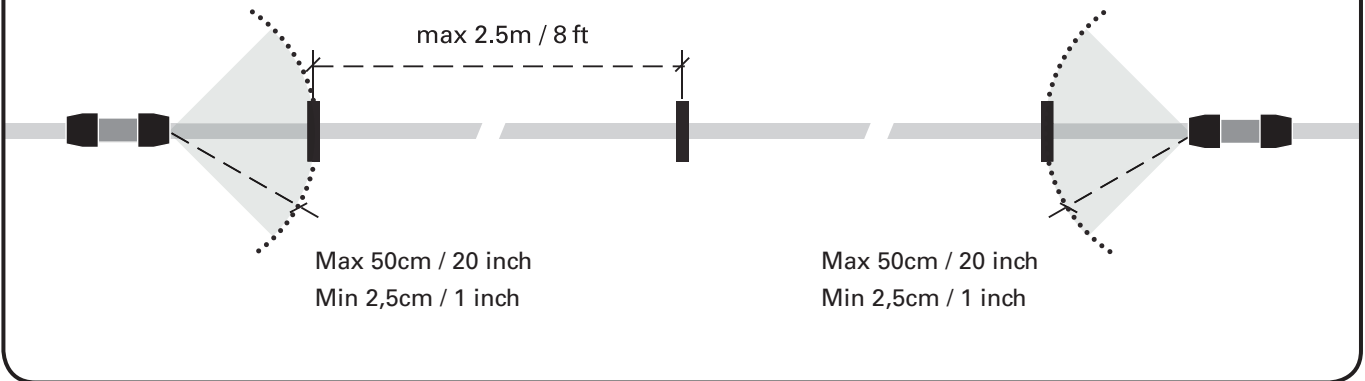

**Rule #2: Every side of a fitting should have minimum 1 pipeclip within a distance of max 0.5 m / 20"**

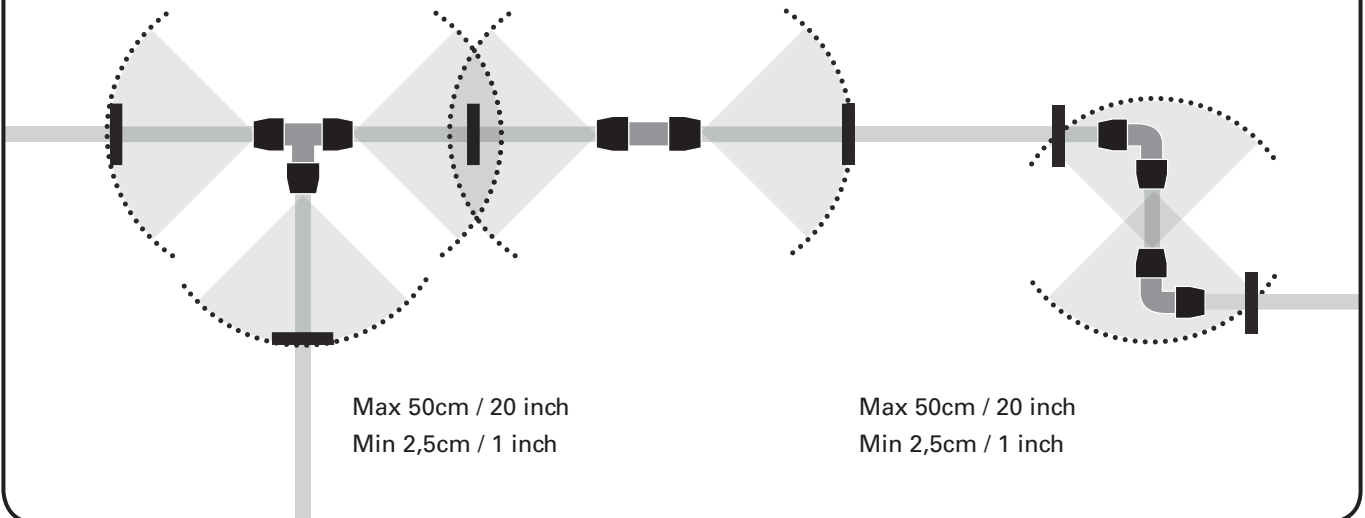

## Valve Support

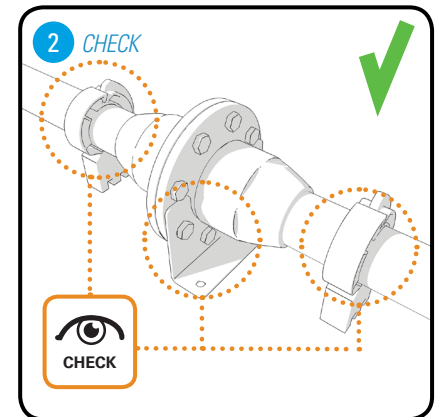
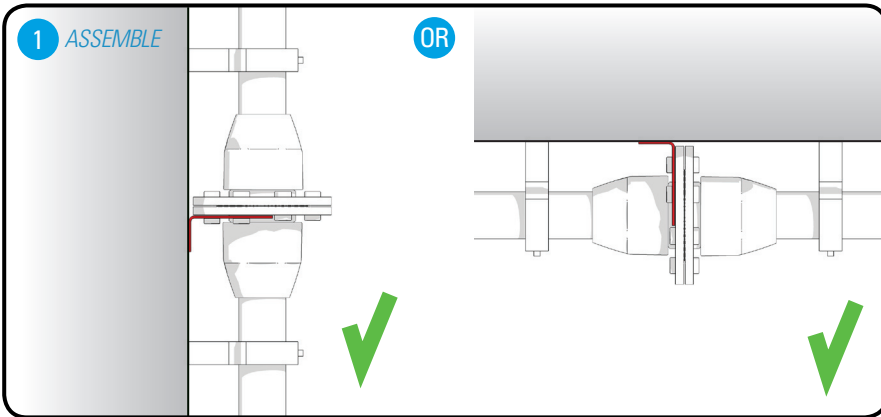
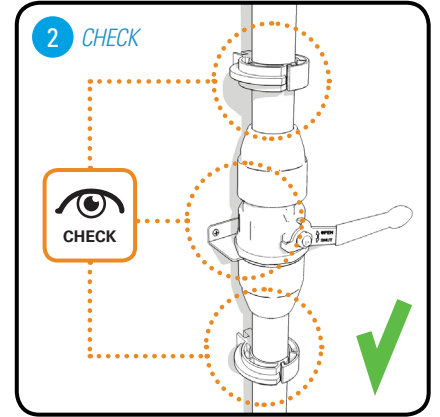
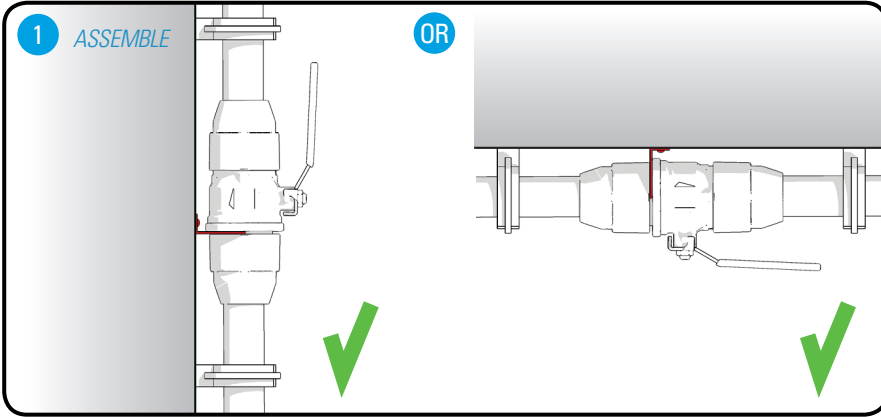



**Conductivity Strip**  
(PF Series only)

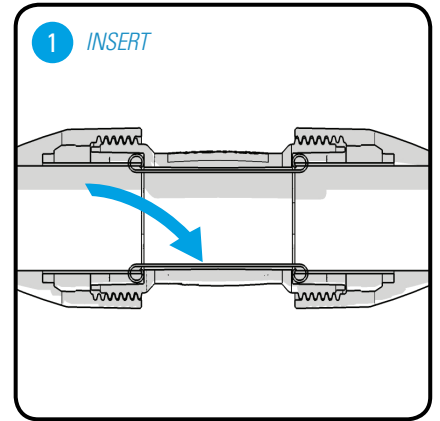
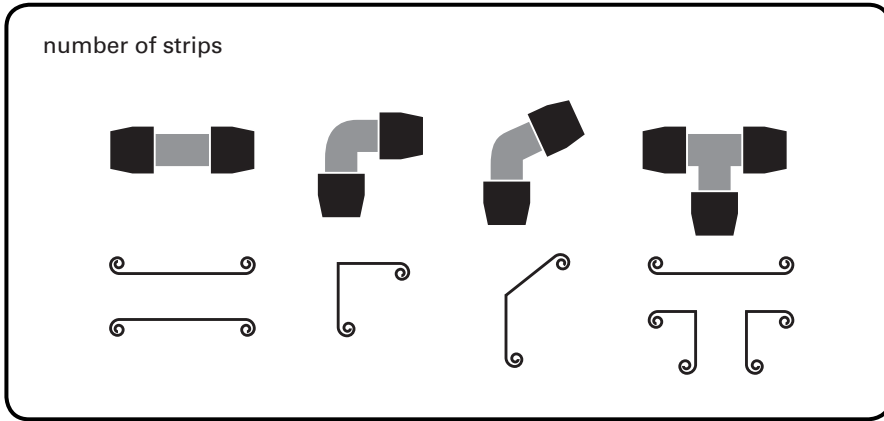

OR

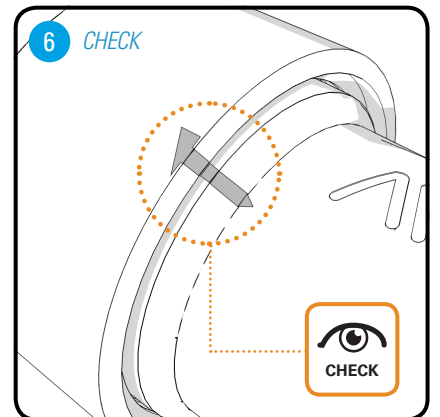
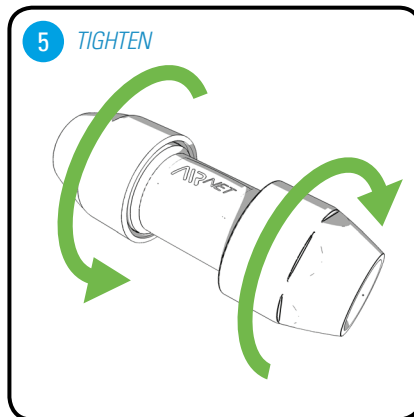
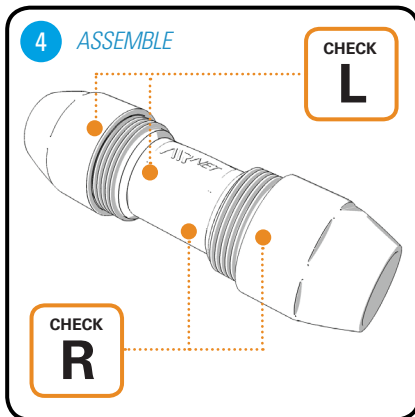
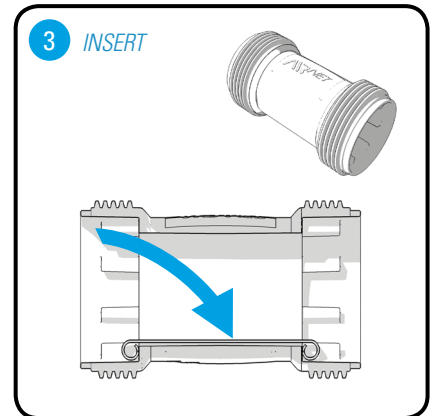
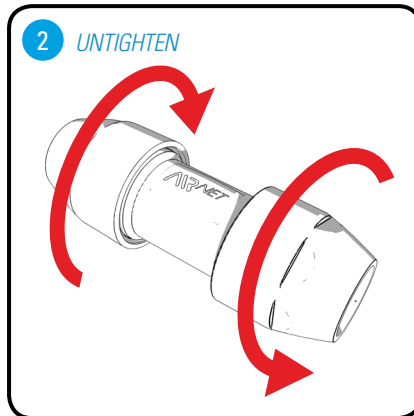
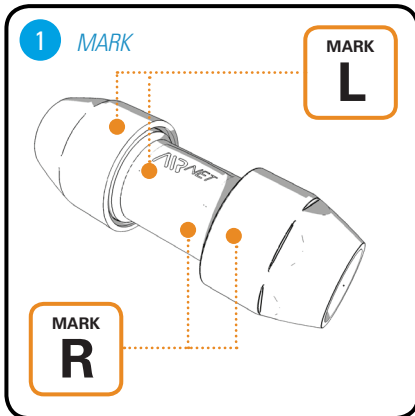

## Adapter Union

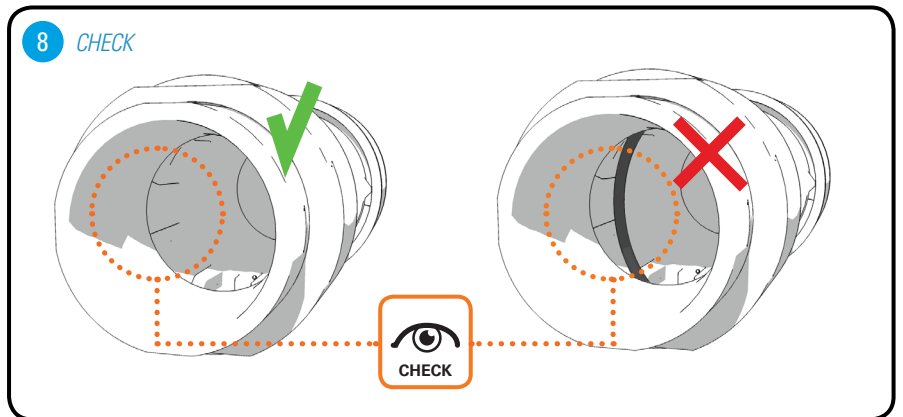
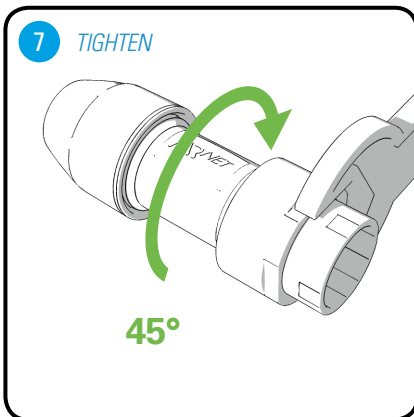
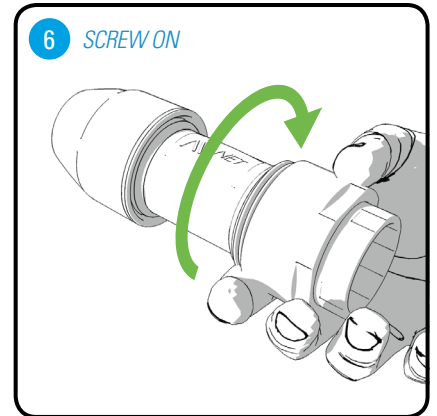
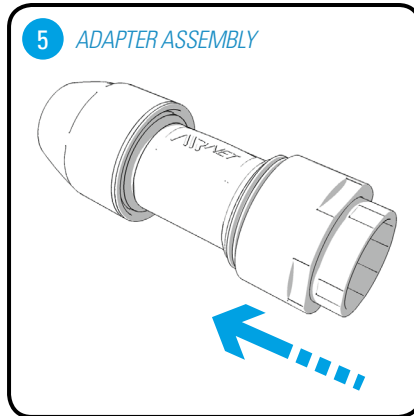
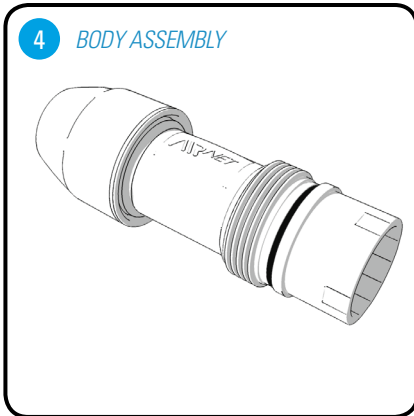
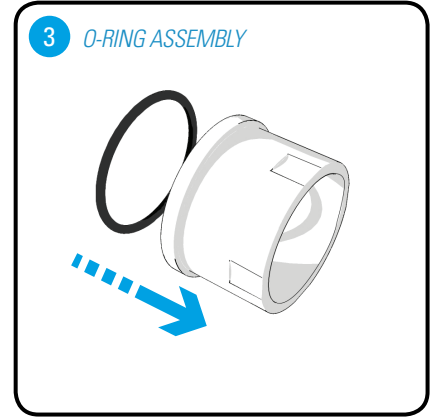
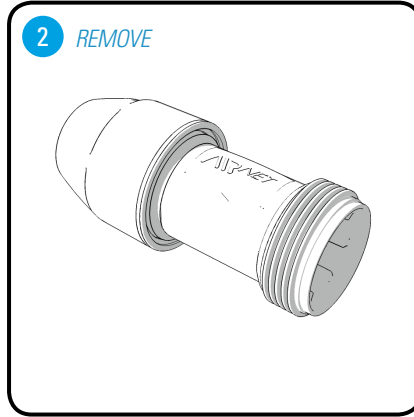
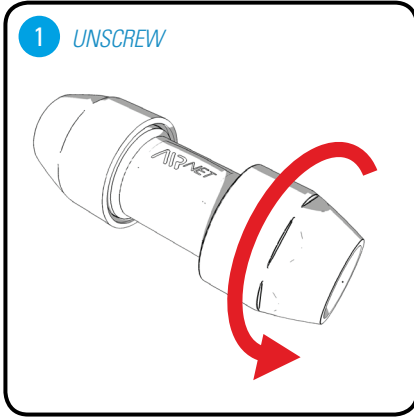

## *fast*

Thanks to a smart design and low weight materials, AIRnet can be installed 70% faster than conventional systems.

## *easy*

AIRnet pipes and fittings are assembled in just a few steps by a single installer, without the need for heavy machinery.

## *reliable*

The durable, corrosion-free AIRnet pipes and fittings come with a 10-year warranty. Low friction and seamless connections minimize pressure drop.



### *Your Dealer*