

Instruction and operation manual

S418

**Thermal mass flow sensor
(with data logger)**

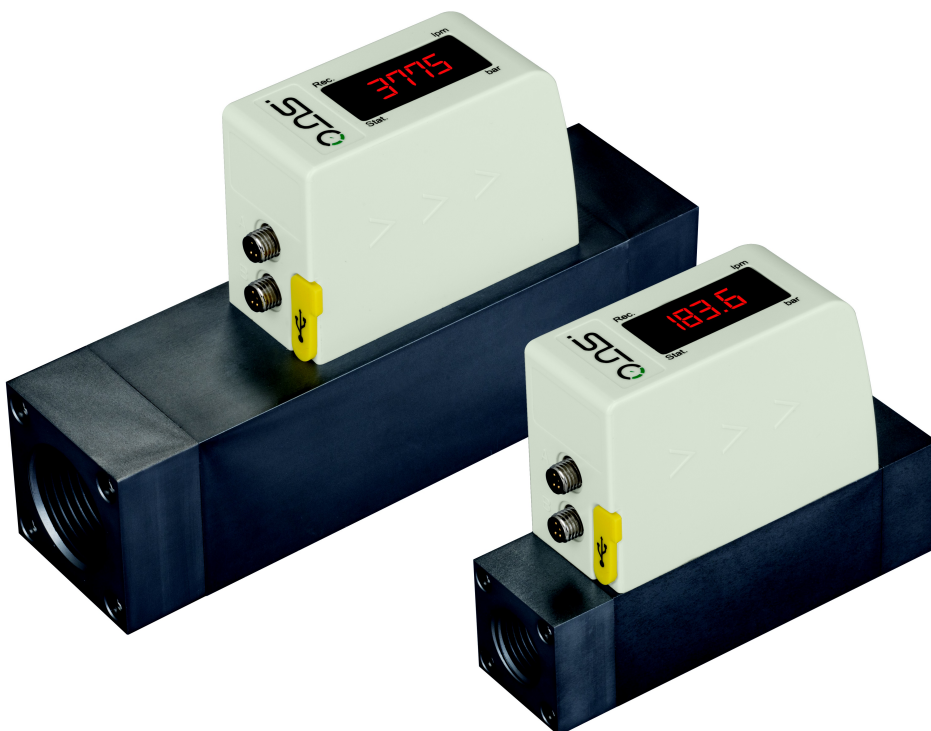

Dear Customer,

Thank you for choosing our product.

Before you start up the device, please read the operating instructions in full and carefully observe them. The manufacturer cannot be held liable for any damage which occurs as a result of non-observance or non-compliance with this manual.

Should the device be tampered with in any manner other than a procedure which is described and specified in the manual, the warranty is canceled and the manufacturer is exempt from liability.

The device is destined exclusively for the described application.

SUTO offers no guarantee for the suitability for any other purpose. SUTO is also not liable for consequential damage resulting from the delivery, capability or use of this device.

Table of contents

1 Safety instructions.....	4
2 RF exposure information and statement.....	6
3 Application.....	7
4 Features.....	7
5 Technical Data.....	8
5.1 General data.....	8
5.2 Electrical data.....	9
5.3 Data logger.....	9
5.4 Output signals.....	9
5.5 Accuracy	10
5.6 Additional data for models with pressure sensor.....	10
6 Dimensional drawing.....	11
7 Installation.....	12
7.1 Installation considerations.....	12
7.2 LED indicators.....	13
7.3 Electrical connection.....	14
8 Sensor signal outputs.....	15
8.1 Analog output.....	15
8.2 Pulse output.....	15
8.3 Modbus output.....	17
9 Configuration.....	18
10 Data logging.....	19
10.1 Features.....	19
10.2 Operations.....	20
10.2.1 Logger configuration.....	20
10.2.2 Log analysis and export.....	20
11 Calibration.....	21
12 Disposal or waste.....	21
13 Warranty.....	22
Appendix A Specifications.....	23
A.1 Flow ranges.....	23
A.2 Error codes.....	25
Appendix B Modbus communication example.....	26
Appendix C LRC and CRC calculation.....	28

1 Safety instructions

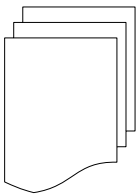

Please check if this instruction manual accords to the product type.

Please observe all notes and instructions indicated in this manual. It contains essential information which must be observed before and during installation, operation and maintenance. Therefore this instruction manual must be read carefully by the technician as well as by the responsible user / qualified personnel.

This instruction manual must be available at the operation site of the flow sensor at any time. In case of any obscurities or questions, regarding this manual or the product, please contact the manufacturer.

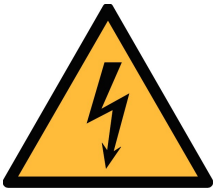

WARNING!

Compressed air!

Any contact with quickly escaping air or bursting parts of the compressed air system can lead to serious injuries or even death!

- Do not exceed the maximum permitted pressure range (see sensors label).
- Only use pressure tight installation material.
- Avoid that persons get hit by escaping air or bursting parts of the instrument.
- The system must be pressureless during maintenance work.



WARNING!

Voltage used for supply!

Any contact with energized parts of the product, may lead to an electrical shock which can lead to serious injuries or even death!

- Consider all regulations for electrical installations.
- The system must be disconnected from any power supply during maintenance.
- Any electrical work on system is only allowed by authorized qualified personal.

**ATTENTION!****Permitted operating parameters!**

Observe the permitted operating parameters, any operation exceeding this parameters can lead to malfunctions and may lead to damage on the instrument or the system.

- Do not exceed the permitted operating parameters.
- Make sure the product is operated in its permitted limitations.
- Do not exceed or undercut the permitted storage and operation temperature and pressure.
- The product should be maintained and calibrated frequently, at least annually.

General safety instructions

- It is not allowed to use the product in explosive areas.
- Please observe the national regulations before/during installation and operation.

Remarks

- It is not allowed to disassemble the product.

**ATTENTION!****Measurement values can be affected by malfunction!**

The product must be installed properly and frequently maintained, otherwise it may lead to wrong measurement values, which can lead to wrong results.

- Always observe the direction of the flow when installing the sensor. The direction is indicated on the housing.
- Do not exceed the maximum operation temperature at the sensors tip.
- Avoid condensation on the sensor element as this will affect accuracy enormously.

Storage and transportation

- Make sure that the transportation temperature is between -30 ... +70 °C.

- For storage and transportation it is recommended to use the packaging which comes with the sensor.
- Make sure that storage temperature of the sensor is between -10 ... +50°C.
- Avoid direct UV and solar radiation during storage.
- For the storage the humidity must be <90% with no condensation.

2 RF exposure information and statement

This equipment complies with FCC RF radiation exposure limits set forth for an uncontrolled environment. This equipment should be installed and operated with minimum distance of 20 cm between the radiator and your body.

This device complies with part 15 of the FCC rules. Operation is subject to the following two conditions: (1) this device may not cause harmful interference, and (2) this device must accept any interference received, including interference that may cause undesired operation.

NOTE: The manufacturer is not responsible for any radio or TV interference caused by unauthorized modifications to this equipment. Such modifications could void the user's authority to operate the equipment.

NOTE: This equipment has been tested and found to comply with the limits for a Class B digital device, pursuant to part 15 of the FCC Rules. These limits are designed to provide reasonable protection against harmful interference in a residential installation. This equipment generates uses and can radiate radio frequency energy and, if not installed and used in accordance with the instructions, may cause harmful interference to radio communications. However, there is no guarantee that interference will not occur in a particular installation. If this equipment does cause harmful interference to radio or television reception, which can be determined by turning the equipment off and on, the user is encouraged to try to correct the interference by one or more of the following measures:

- Reorient or relocate the receiving antenna.
- Increase the separation between the equipment and receiver.
- Connect the equipment into an outlet on a circuit different from that to which the receiver is connected.

- Consult the dealer or an experienced radio/TV technician for help
- This device and its antenna(s) must not be co-located or operating in conjunction with any other antenna or transmitter.

3 Application

The S418 is a thermal mass flow sensor which is designed to measure the consumption of compressed air and other gases within the permissible operating parameters. These parameters can be found in the technical data section.

The S418 can measure the following parameters:

- Volumetric flow
- Total consumption
- Temperature of the fluid
- Pressure of the fluid (optional)

The default factory settings are:

- Volumetric flow in l/min
- Consumption in m³
- Temperature in °C
- Pressure in bar

Other units are configurable using the service App S4C-FS which can be downloaded from the Google Play Store or our Website.

4 Features

- Inline thermal mass flow sensor virtually independent of pressure and temperature changes.
- Process connection of G-type thread with DN8, DN15, DN20 and DN25 available
- Very short response time.
- Particularly suitable for measuring at the point-of-use flow and consumption of compressed air and other gases.
- Integrated display showing volumetric flow.
- Options for output signals:

- Analogue 4 ... 20 mA and pulse output
- Modbus interface
- M-Bus interface
- BlueTooth interface for remote sensor settings
- Configurable through Android devices
- Data logger capable of recording 5-million measurement samples

5 Technical Data

5.1 General data

 FCC ID: 2ASK2-SUTO-003	
Parameters	Volumetric flow: l/min, m ³ /h, m ³ /min, cfm Consumption: m ³ , ft ³ Medium temperature: °C, °F Medium pressure: bar, psi
Reference conditions	Selectable by users. Default ex-factory settings: <ul style="list-style-type: none"> • Compressed air: ISO1217 20°C, 1000 hPa • Other gas: DIN1343 0°C, 1013.25 hPa
Principle of measurement	Thermal mass flow
Sensor	Glass coated resistive sensor
Measured gases	Non-corrosive gases, up to 2 calibrated gases
Ambient temperature /Transport temperature	0 ... +50°C / -30 ... +70°C
Medium conditions	0 ... +50°C, rH<90%, no condensation
Operating pressure	0 ... 1.0 MPa
Pressure drop	Maximum pressure drop at the maximum flow of Standard (S) flow range: <ul style="list-style-type: none"> • DN8 type : 30 hPa • DN15 type: 100 hPa • DN20 type: 100 hPa • DN25 type: 200 hPa
Casing	Process connection: aluminum alloy Wetted parts: aluminum alloy

	Top casing: PC + ABS
Protection class	IP54
Dimensions	See dimensional drawing on page 11.
Display	4-digit LED display
Tube diameter	DN8, DN15, DN20, DN25
Process connection:	G inner thread ISO 228-1
Weight	0.43 kg (DN8), 0.46 kg (DN15) 0.96 kg (DN20), 0.97 kg (DN25)

5.2 Electrical data

Power supply	15 ... 30 VDC, 120 mA @ 24 VDC
--------------	--------------------------------

5.3 Data logger

Memory size	Up to 8,000,000 samples.
Recording channels	Up to 4: flow, consumption, temperature and pressure.
Logger programming	Use the Android app S4C-FS (Free for download on Google Play Store)
Logger readout	Use windows-based software S4A via USB (Free for download on the SUTO Website)

5.4 Output signals

Analogue output	Signal: 4 ... 20 mA, isolated Scaling: 0 to max flow Max load: 250R
Pulse output	1 pulse per consumption unit (m ³ or ft ³) isolated switch, max. 30 VDC, 200 mA (pulse length: 10 ... 120 ms, depends on flow rate)
Modbus output	See chapter 8.3 Modbus output

5.5 Accuracy

Accuracy* (at 6 bar, 20°C, rH<40%)	$\pm (1.5\% \text{ of reading} + 0.3\% \text{ FS})$
Temperature coefficient	$< 0.1\%/K \text{ FS}$
Pressure coefficient	$< 5\% / 1 \text{ MPa}$
Turndown ratio	100:1
Stated accuracy at	Ambient/process temperature $23^\circ\text{C} \pm 3^\circ\text{C}$ Ambient/process humidity $< 90\%$ Process pressure at 0.6 MPa
Repeatability	$\pm 0.5\% \text{ of reading}$
Sampling rate	10 samples per second

* The specified accuracy is valid only within the minimum and maximum flow rates that are indicated in Appendix A.1.

5.6 Additional data for models with pressure sensor

Accuracy	$\pm 0.5\% \text{ FS}$
Parameters	Pressure: bar (default) or psi
Sensor	Piezzo-resistive sensor
Measuring range	0 ... 1.0 MPa

6 Dimensional drawing

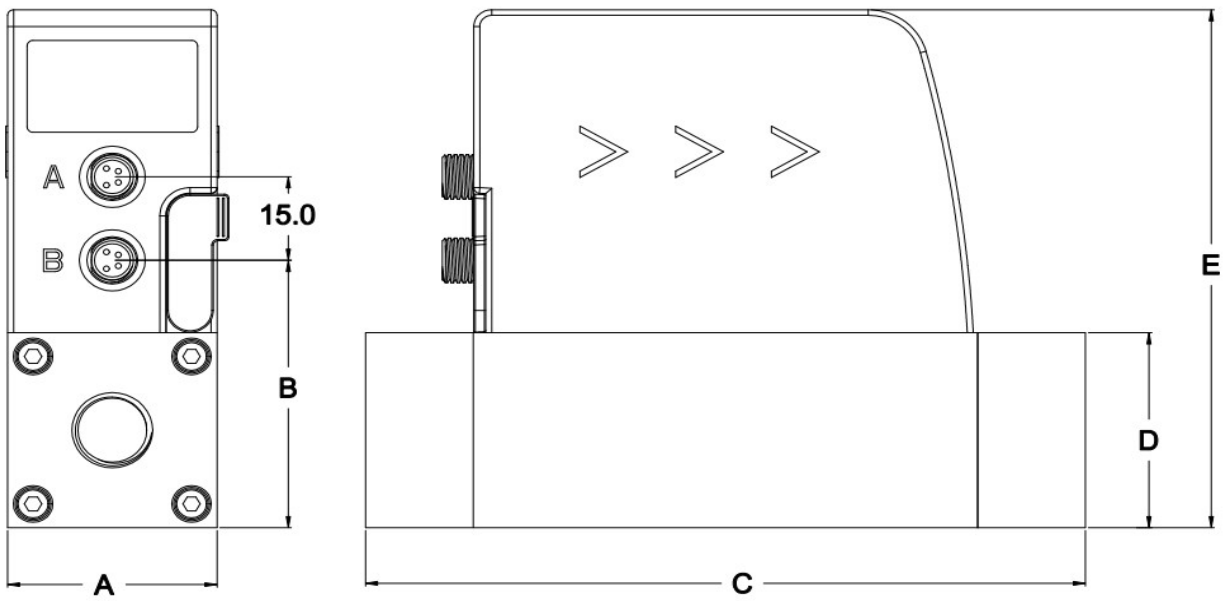

	A (mm)	B (mm)	C (mm)	D (mm)	E (mm)
DN 8/15	35.0	48.0	120.4	35.0	93.0
DN 20/25	48.0	61.0	178.0	48.0	106.0

7 Installation

S418 is delivered with following components:

Qty.	Description	Order no.
		S695 4180
		S695 4181
		S695 4182
1	S418 Thermal mass flow meter	S695 4183
		S695 4185
		S695 4186
		S695 4187
		S695 4188
1	5 m cable with M8 connector and open ends	A553 0136
1	USB cable	A553 0130
1	Instruction and operation manual	No P/N
1	Calibration certificate	No P/N

7.1 Installation considerations

To maintain the accuracy stated in the technical data, the sensor must be installed inline and fitted to tubes with the same diameter.

- The sensor is for indoor use only! At an outdoor installation, the sensor must be protected from solar radiation and rain.
- It is strongly recommend not to install S418 permanently in the wet environment which exists usually right after a compressor outlet.

7.2 LED indicators

The S418 provides four LED indicators on the display panel, which indicate the status of the data logger, display, and Bluetooth connection separately.

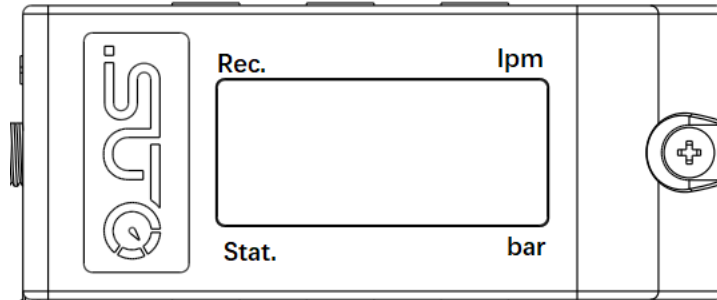

LED	Function	Status
Rec	Indicator for the logger state	On: NAND flash is formatting. Flashing: Data logger is working
lpm	Indicator for the display state (volumetric flow)	On: The display is showing the volumetric flow rate. Flashing: N/A
stat.	Indicator for the Bluetooth state	On: The Bluetooth is connected. Flashing: N/A
bar	Indicator for the display state (pressure)	On: The display is showing the pressure value. Flashing: N/A

7.3 Electrical connection

The flow sensor comes with two connector plugs "A" and "B". By default the sensor is delivered with one 5 m cable with a M8 connector on one side and open wires on the other side. To operate the S418, one cable connection is sufficient. However if the pulse output is to be used or the supply and signal should be on separate cables, a second connection cable must be ordered.

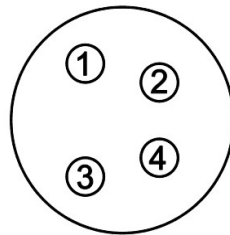
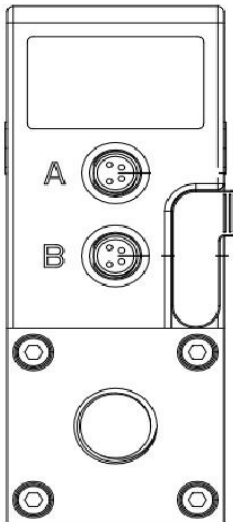

Legend to pin assignment

GND:	Ground for Modbus
-VB:	Negative supply voltage
+VB:	Positive supply voltage
I+:	Positive 4 ...20 mA signal
I-:	Negative 4 ... 20 mA signal
D+:	Modbus data +
D-:	Modbus data -
P:	Pulse signal
M:	M-Bus data
NA:	Not Applicable

Pin assignment connector plug M8

Output Version	Connector	Pin 1	Pin 2	Pin 3	Pin 4
Modbus	A	D-	-VB	+VB	D+
	B	D-	GND	GND	D+
Pulse and analog	A	I-	-VB	+VB	I+
	B	I-	P	P	I+
M-Bus	A	M	-VB	+VB	M
	B	M	NA	NA	M
Wire color		brown	white	blue	black



ATTENTION!

Do not screw the M8 plug using force. Otherwise, it may damage the connecting pins.

8 Sensor signal outputs

8.1 Analog output

The sensor has an analog output with a range of 4 ... 20 mA. This output can be scaled to match a desired measuring range. Standard scaling is from 0 to the max flow. The corresponding flow in different pipe sizes can be found in Appendix A.

8.2 Pulse output

The sensor will send out one pulse per consumption unit. This pulse output can be connected to an external pulse counter to count the total consumption. The number of m³ per second are summed up and indicated after one second. Pulse length depends on flow rate.

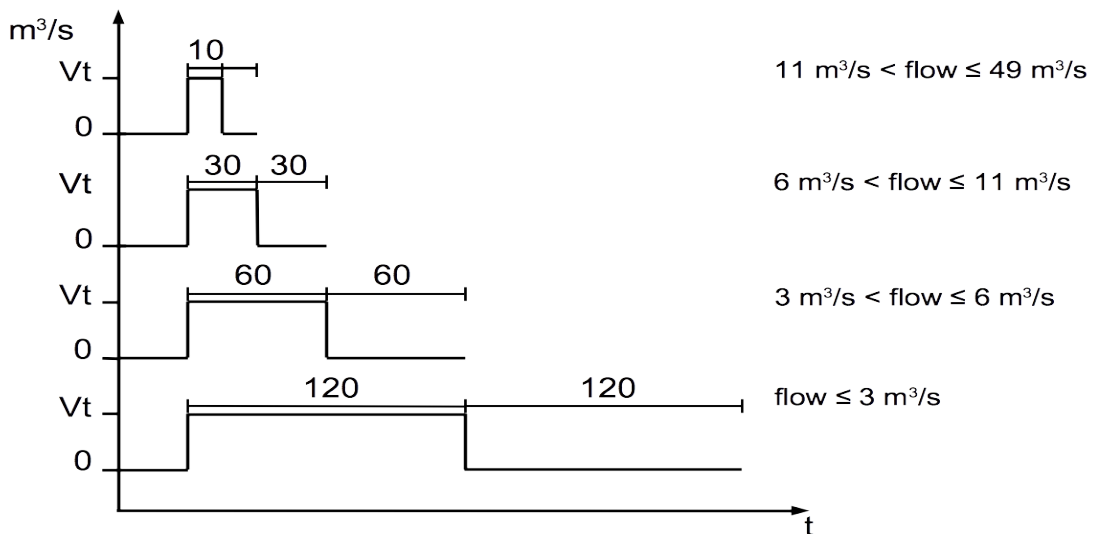
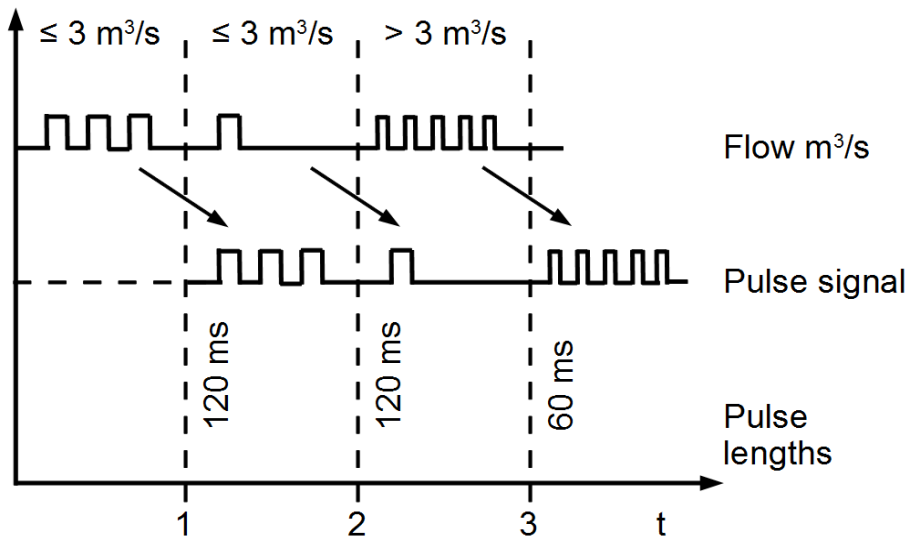

Volumetric flow [m ³ /s]	Volumetric flow [m ³ /h]	Pulse length [ms]	Max. pulse output per hour
≤ 3	≤ 10800	120	1080
> 3	> 10800	60	2880
> 6	> 21600	30	3960

Pulse connection diagram

Variant 1:

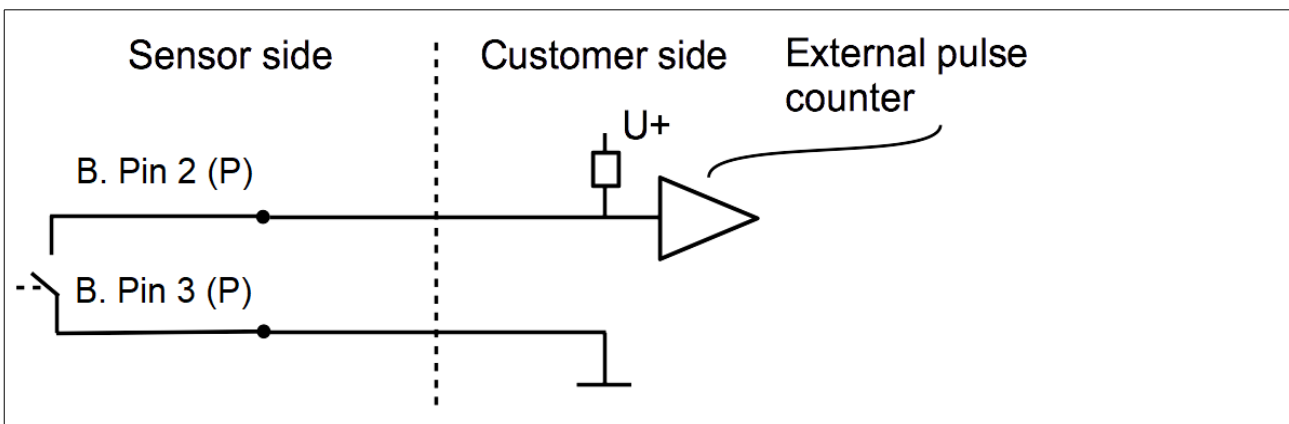

Variant 2:

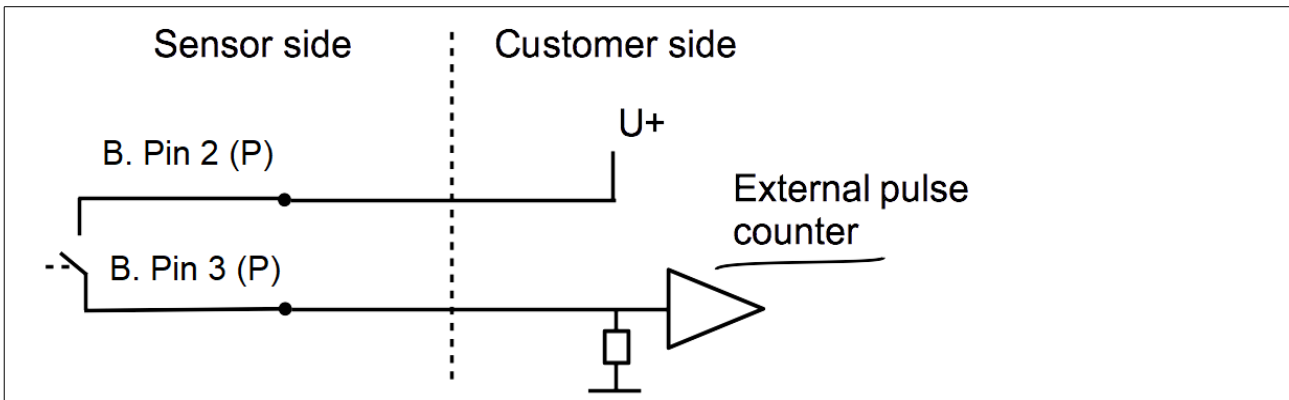

8.3 Modbus output

Mode : RTU
 Baud rate : 19200
 Device address : 1
 Framing / parity / stop bit : 8, N, 1
 Response timeout : 1 second
 Response delay : 0 ms
 Inter-frame spacing : 7 char

Remarks

Modbus communication settings can be changed by the service app **S4C-FS**.

Index	Channel description	Resolution	Format	Length	Modbus address
1	Flow	0.1	FLOAT	4-byte	6
2	Consumption	1	UNIT32	4-byte	8
3	Temperature	0.1	FLOAT	4-byte	0
4	Pressure	0.01	FLOAT	4-byte	2

Remarks

- All numbers are in little-endian format.
- Function code: 03.
- The measurement value is always available in the programmed physical unit.

9 Configuration

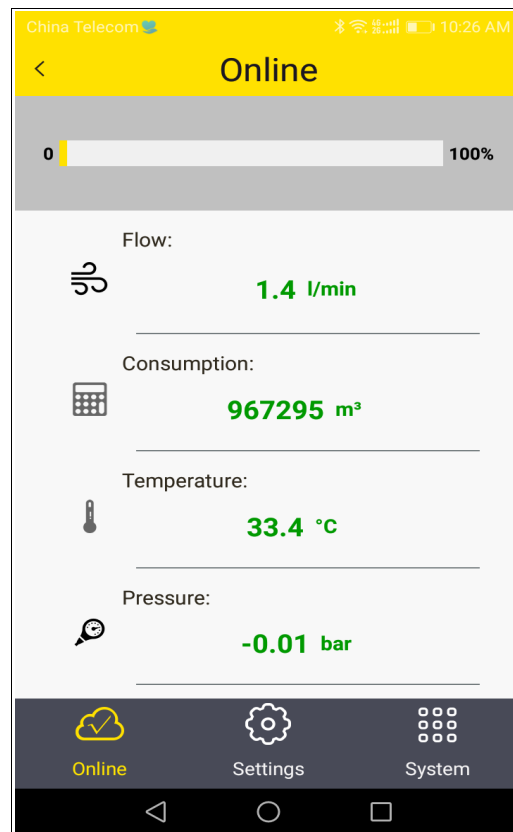

To change any settings on the S418, please download and install the service App **S4C-FS** which is available on the Google Play store or our Website. This App runs on any Android system with BlueTooth supported.

To be allowed to change settings, the App needs to scan the QR code on the calibration certificate at first. This ensures that only valid users can access the sensor settings. For more information about instructions, see the *S4C-FS Instruction and operation manual*.



ATTENTION!

Changes on the settings may lead to wrong measurement results! Contact manufacturer in case you are not familiar with the settings.

10 Data logging

The S418 provides the data logger function to help you record and analyze data measured over time.

10.1 Features

Before you use the data logger, learn about how it works:

- You can use the Android App S4C-FS to enable or disable the data logger function and set a sampling rate as needed.
- By default the data logger is disabled. Once you enable the data logger, the S418 starts logging data. Once you disable the data logger, the S418 stops logging.
- The S418 saves all sampled data records into one file. Each record includes a time stamp and all measurement data sampled at this time point, such as flow, consumption, pressure and temperature.
- The S418 log file supports up to 5.6 million records due to its memory size, which is equivalent to 64-day data at the one-second sampling rate.
- When the S418 runs out of memory, the new record will replace the oldest one.
- To read out the logs recorded in the S418 memory, install S4A (1.1.2 or later versions), which is a specialized log analysis software from SUTO, on a Windows-based computer. Also, connect the PC with the S418 through the USB port.
- Data records are saved in one file in the S418, S4A reads them out into one file as well unless the following situations occur:
 - When the sampling rate is changed, S4A reads out the data records into a different file.
 - When the S418 stops logging (for example, poweroff) and resumes in less than 24 hours, S4A still reads out the data records into one file; However, if the time gap is larger than 24 hours, S4A reads out the new data records to a different file.
- S4A enables you to have a graphic view on measurement data recorded in a log file.

10.2 Operations

10.2.1 Logger configuration

You can control and configure the S418 data logger by using the S4C-FS App. Detailed steps are as follows.

1. Install and launch the **S4C-FS** App.

For more information, see the *S4C-FS Instruction and Operation Manual*.

2. On the S4C-FS App, access **Settings** > **Logger Settings** and then perform all logger-related operations as described below.

Parameter	Description
Logger Status	To start or stop the logger.
Start Date & Time	To view the time stamp of the first log recorded.
Stop Date & Time	To view the time stamp of the last log recorded.
Number of Samples	To view the number of log records in the S418 data logger.
Sampling Rate(mm:ss)	To specify the sampling rate.

10.2.2 Log analysis and export

To enable you to read, analyze and export the measurement data recorded in the S418, SUTO provides the log analysis software S4A. To purchase S4A, please contact your local distributor.

The following steps show you how to install S4A and use it to analyze and export log files.

1. Download the S4A software from **Support** > **Downloads** > **Apps** on the SUTO Website (<http://www.suto-itec.com>).
2. Install the software on your computer by double clicking the downloaded EXE file.
3. Launch the S4A software.
4. Click the **Detect** menu to detect and build the communication with the S418.
5. Click the **Read** menu to read out data records logged during a time period that you specify.

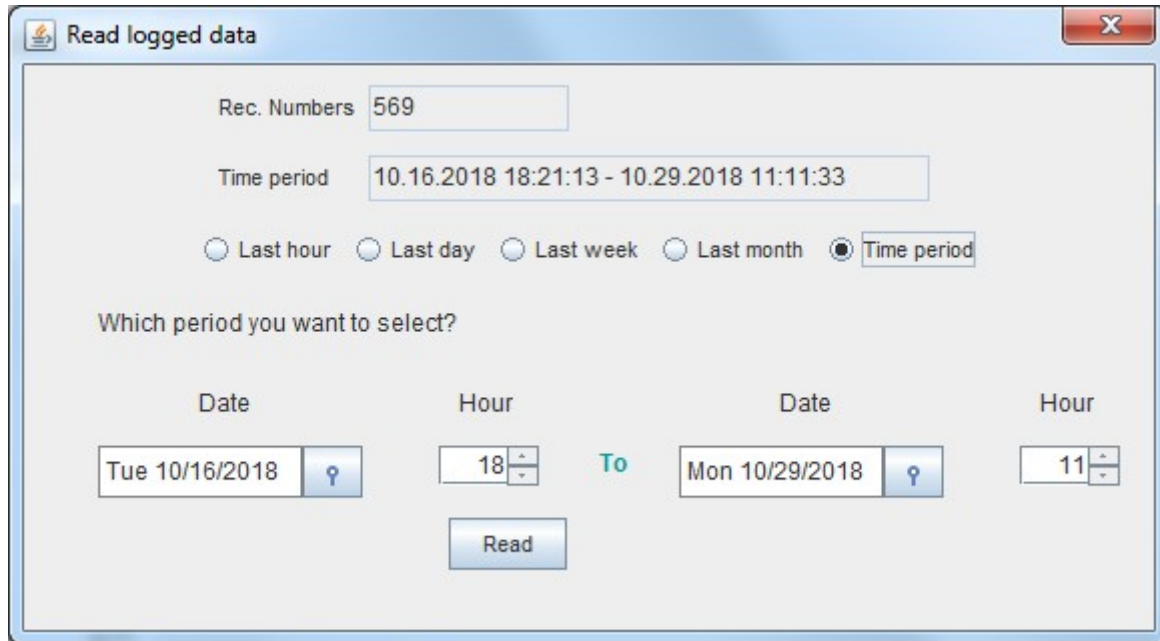

6. Click the **File** menu to have graphic views on measurement data in a log file; and if needed, to export this log file to the Excel or CSV format.

For more information about operations on S4A, click the **Help** button on the top right corner.

11 Calibration

The sensor is calibrated ex work. The exact calibration date is printed on the certificate which is supplied together with the sensor. The accuracy of the sensor is regulated by the on site conditions, parameters like oil, high humidity or other impurities can affect the calibration and furthermore the accuracy. However we recommend to calibrate the instrument at least once per year. The calibration is excluded from the instruments warranty. For this please contact the manufacturer.

12 Disposal or waste



Electronic devices are recyclable material and do not belong in the household waste.

The sensor, the accessories and its packings must be disposed according to your local statutory requirements. The dispose can also be carried by the manufacturer of the product, for this please contact the manufacturer.

13 Warranty

SUTO provides a warranty for this product of 24 months covering the material and workmanship under the stated operating conditions from the date of delivery. Please report any findings immediately and within the warranty time. If faults occur during the warranty time, SUTO will repair or replace the defective unit, without charge for labour and material costs but there is a charge for other service such as transport and packing costs.

Excluded from this warranty is:

- Damage caused by:
 - Improper use and non-adherence to the instruction manual.
 - Use of unsuitable accessories.
 - External influences (e.g. damage caused by vibration, damage during transportation, excess heat or moisture).

The warranty is canceled:

- If the user opens the measurement instrument without a direct request written in this instruction manual.
- If repairs or modifications are undertaken by third parties or unauthorized persons.
- If the serial number has been changed, damaged or removed.

Other claims, especially those for damage occurring outside the instrument are not included unless responsibility is legally binding.

Warranty repairs do not extend the period of warranty.



ATTENTION!

Batteries have a reduced warranty time of 12 month.

Appendix A Specifications

A.1 Flow ranges

Flow ranges in sl/min of **air** at ISO 1217: 20°C and 1000 mbar:

	DN8		DN15		DN20		DN25	
	Min	Max	Min	Max	Min	Max	Min	Max
Standard range (S)	2.5	250	10	1000	20	2000	35	3500
Low range (L)	0.5	50	2	200	4	400	7	700

Flow ranges in sl/min of **N₂** at 0°C and 1013.25 mbar:

	DN8		DN15		DN20		DN25	
	Min	Max	Min	Max	Min	Max	Min	Max
Standard range (S)	2.22	222	8.9	890	17.8	1780	31.1	3110
Low range (L)	0.45	44.5	1.78	178	3.56	356	6.22	622

Flow ranges in sl/min of **O₂** at 0°C and 1013.25 mbar:

	DN8		DN15		DN20		DN25	
	Min	Max	Min	Max	Min	Max	Min	Max
Standard range (S)	2.38	238	9.53	953	19.07	1907	33.37	3337
Low range (L)	0.45	47.7	1.91	191	3.81	381	6.67	667

ATTENTION: Oil-and grease-free cleaning is required.

Tip: To determine measuring range for other gases, you can use the tool "Flow range calculator" which is available for download on our Website.

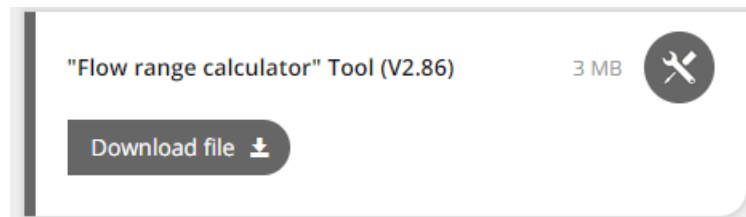

Order Table						
Order no.	Size	Range	Output	Gas 1	Gas 2	Description
S695 418						S418, thermal mass flow meter, 1.5% o.RDG., 24 VDC
	0					DN8 G inner thread
	1					DN15 G inner thread
	2					DN20 G inner thread
	3					DN25 G inner thread
	5					DN8 G inner thread, inc. pressure
	6					DN15 G inner thread, inc. pressure
	7					DN20 G inner thread, inc. pressure
	8					DN25 G inner thread, inc. pressure
		S				Standard range version of S418
A1453		L				Low range version of S418
A1455			A			Analogue 4 ... 20 mA, pulse
A1456			B			Digital Modbus/RTU
A1457			C			Digital M-Bus
				A-Z	B-Z	See gas table below
A1459						S418 with imperial units instead of SI units

Accessories	
Order no.	description
A554 3315	T-BOX for S415/418 Modbus/M-Bus systems, including 2 m cable with M8 connector
A554 0109	Mains power supply 100-240 VAC / 24 VDC, 0.5 A, 2 m cable with M8 connector
A553 0137	Connection cable S415/418 to S551, 5 m
M599 7020	S4A data analysis software, supports USB

Gas table	
	Gas type
A	Air
B	CO ₂
C	O ₂ (oil & grease free)
D	N ₂
E	N ₂ O
F	Ar
G	Natural gas (mix ratio)
H	H ₂
I	Other gas (specify)
J	He (real gas calibration)
K	C ₃ H ₈
Z	No second gas

A.2 Error codes

When an error code shows on the LED display, use the following table to identify the error cause.

Error code	Description
Er. 01	Real time clock failure
Er. 02	ADC failure
Er. 04	EEPROM failure
Er. 08	NAND flash failure
Er. 10	Pressure sensor failure

Error code	Description
Er. 20	Flow sensor failure
Er. 30	Temperature sensor failure
Er. 40	Bluetooth failure
Er. 50	Logger failure

Appendix B Modbus communication example

03 (0x03) Read holding register

Request

Response

Slave address	1 byte	Slave address	1 byte
Function code	1 byte	Function code	1 byte
Starting address Hi	1 byte	Byte count	1 byte
Starting address Lo	1 byte	Register Hi	1 byte
No. of points Hi	1 byte	Register Lo	1 byte
No. of points Lo	1 byte	:	:
CRC	2 bytes	Register Hi	1 byte
		Register Lo	1 byte
		CRC	2 bytes

05 (0x05) Write single coil

Request

Response

Slave address	1 byte	Slave address	1 byte
Function code	1 byte	Function code	1 byte
Coil address Hi	1 byte	Coil address Hi	1 byte
Coil address Lo	1 byte	Coil address Lo	1 byte
Data Hi	1 byte	Data Hi	1 byte
Data Lo	1 byte	Data L	1 byte
CRC	2 bytes	CRC	2 bytes

16 (0x10) Write multiple registers

Request		Response	
Slave address	1 byte	Slave address	1 byte
Function code	1 byte	Function code	1 byte
Starting address Hi	1 byte	Starting address Hi	1 byte
Starting address Lo	1 byte	Starting address Lo	1 byte
No. of registers Hi	1 byte	No. of registers Hi	1 byte
No. of registers Lo	1 byte	No. of registers Lo	1 byte
Byte count	1 byte	CRC	2 bytes
Data Hi	1 byte		
Data Lo	1 byte		
:	:		
Data Hi	1 byte		
Data Lo	1 byte		
CRC	2 bytes		

17 (0x11) Report slave ID

Request		Response	
Slave address	1 byte	Slave address	1 byte
Function code	1 byte	Function code	1 byte
CRC	2 bytes	Byte count	1 byte
		Slave ID	2 bytes
		Device run indicator	2 bytes
		Product code	2 bytes
		Product name	20 bytes
		CRC	2 bytes

Appendix C LRC and CRC calculation

LRC generation

The Longitudinal Redundancy Checking (LRC) field is one byte, containing an 8-bit binary value. The LRC value is calculated by the transmitting device, which appends the LRC to the message. The device that receives recalculates an LRC during receipt of the message, and compares the calculated value to the actual value it received in the LRC field. If the two values are not equal, an error results.

The LRC is calculated by adding together successive 8-bit bytes in the message, discarding any carries, and then two's complementing the result. The LRC is an 8-bit field, therefore each new addition of a character that would result in a value higher than 255 decimal simply 'rolls over' the field's value through zero. Because there is no ninth bit, the carry is discarded automatically.

A procedure for generating an LRC is:

1. Add all bytes in the message, excluding the starting 'colon' and ending CRLF. Add them into an 8-bit field, so that carries will be discarded.
2. Subtract the final field value from FF hex (all 1's) to produce the ones-complement.
3. Add 1 to produce the twos-complement.

Placing the LRC into the Message

When the 8-bit LRC (2 ASCII characters) is transmitted in the message, the high-order character will be transmitted first, followed by the low-order character. For example, if the LRC value is 61 hex (0110 0001):

Colon	Addr	Func	Data Count	Data	Data	Data	Data	LRC Hi	LRC Lo	CR	LF
								"6" 0x36	"1" 0x31		

Example: an example of a C language function performing LRC generation is shown below.

The function takes two arguments:

```
unsigned char *auchMsg; /* A pointer to the message buffer containing binary data
*/
```

```
/* to be used for generating the LRC, */
```

```
unsigned short usDataLen; /* The quantity of bytes in the message buffer. */
```

LRC generation function

```
static unsigned char LRC(unsigned char *auchMsg, unsigned short
usDataLen)
{
    unsigned char uchLRC = 0 ;                /* LRC char initialized */
    while (usDataLen-->0)                    /* pass through message buffer */
        uchLRC += *auchMsg++;                /* add buffer byte without carry */
    return ((unsigned char)(~((char)uchLRC))); /* return twos complement */
}
```

CRC generation

The **C**yclical **R**edundancy **C**hecking (CRC) field is two bytes, containing a 16-bit binary value. The CRC value is first generated by the transmitting device, which appends the CRC to the message. The device that receives recalculates a CRC during receipt of the message, and compares the calculated value to the actual value it received in the CRC field. If the two values are not equal, an error results.

There are many ways of calculating a CRC checksum. To ensure correct calculation, please refer to [Reference 1] Modbus over serial line, where detailed descriptions and programming examples are available. Even more information and programming examples in different programming languages can be found on: www.modbus.org searching for CRC.

Below is a short text description of how the CRC is calculated. This description is then followed by a C programming example.

1. Load a 16-bit register with FFFF hex (all 1's). Call this the CRC register.
2. Exclusive OR the first 8-bit byte of the message with the low-order byte of the 16-bit CRC register, putting the result in the CRC register.
3. Shift the CRC register one bit to the right (toward the LSB), zero-filling the MSB. Extract and examine the LSB.
4. (If the LSB was 0): Repeat step 3 (another shift). (If the LSB was 1): Exclusive OR the CRC register with the polynomial value 0xA001 (1010 0000 0000 0001).
5. Repeat steps 3 and 4 until 8 shifts have been performed. When this is done, a complete 8-bit byte will have been processed.
6. Repeat steps 2 through 5 for the next 8-bit byte of the message. Continue doing this until all bytes have been processed.

```

0x34, 0xF4, 0x3C, 0xFC, 0xFD, 0x3D, 0xFF, 0x3F, 0x3E, 0xFE, 0xFA, 0x3A, 0x3B,
0xFB, 0x39, 0xF9, 0xF8, 0x38, 0x28, 0xE8, 0xE9, 0x29, 0xEB, 0x2B, 0x2A, 0xEA,
0xEE, 0x2E, 0x2F, 0xEF, 0x2D, 0xED, 0xEC, 0x2C, 0xE4, 0x24, 0x25, 0xE5, 0x27,
0xE7, 0xE6, 0x26, 0x22, 0xE2, 0xE3, 0x23, 0xE1, 0x21, 0x20, 0xE0, 0xA0, 0x60,
0x61, 0xA1, 0x63, 0xA3, 0xA2, 0x62, 0x66, 0xA6, 0xA7, 0x67, 0xA5, 0x65, 0x64,
0xA4, 0x6C, 0xAC, 0xAD, 0x6D, 0xAF, 0x6F, 0x6E, 0xAE, 0xAA, 0x6A, 0x6B, 0xAB,
0x69, 0xA9, 0xA8, 0x68, 0x78, 0xB8, 0xB9, 0x79, 0xBB, 0x7B, 0x7A, 0xBA, 0xBE,
0x7E, 0x7F, 0xBF, 0x7D, 0xBD, 0xBC, 0x7C, 0xB4, 0x74, 0x75, 0xB5, 0x77, 0xB7,
0xB6, 0x76, 0x72, 0xB2, 0xB3, 0x73, 0xB1, 0x71, 0x70, 0xB0, 0x50, 0x90, 0x91,
0x51, 0x93, 0x53, 0x52, 0x92, 0x96, 0x56, 0x57, 0x97, 0x55, 0x95, 0x94, 0x54,
0x9C, 0x5C, 0x5D, 0x9D, 0x5F, 0x9F, 0x9E, 0x5E, 0x5A, 0x9A, 0x9B, 0x5B, 0x99,
0x59, 0x58, 0x98, 0x88, 0x48, 0x49, 0x89, 0x4B, 0x8B, 0x8A, 0x4A, 0x4E, 0x8E,
0x8F, 0x4F, 0x8D, 0x4D, 0x4C, 0x8C, 0x44, 0x84, 0x85, 0x45, 0x87, 0x47, 0x46,
0x86, 0x82, 0x42, 0x43, 0x83, 0x41, 0x81, 0x80, 0x40
};
unsigned short CRC16(unsigned char *puchMsg, unsigned short usDataLen){
    unsigned char uchCRCHi = 0xFF;          /* high byte of CRC initialized
*/
    unsigned char uchCRCLo = 0xFF;        /* low byte of CRC initialized
*/
    unsigned uIndex ;                      /* will index into CRC lookup
table */
    while(usDataLen--)                    /* pass through message
buffer */
    {
        uIndex = uchCRCHi ^ *puchMsg++ ;  /* calculate the CRC */
        uchCRCHi = uchCRCLo ^ uchCRCHi[uIndex] ;
        uchCRCLo = uchCRCLo[uIndex] ;
    }
    return (unsigned short int)((uchCRCHi << 8) | uchCRCLo);
}

```